

Panasonic

**Word
Processor**

OPERATING INSTRUCTIONS

MODEL NO. **KX-W900**

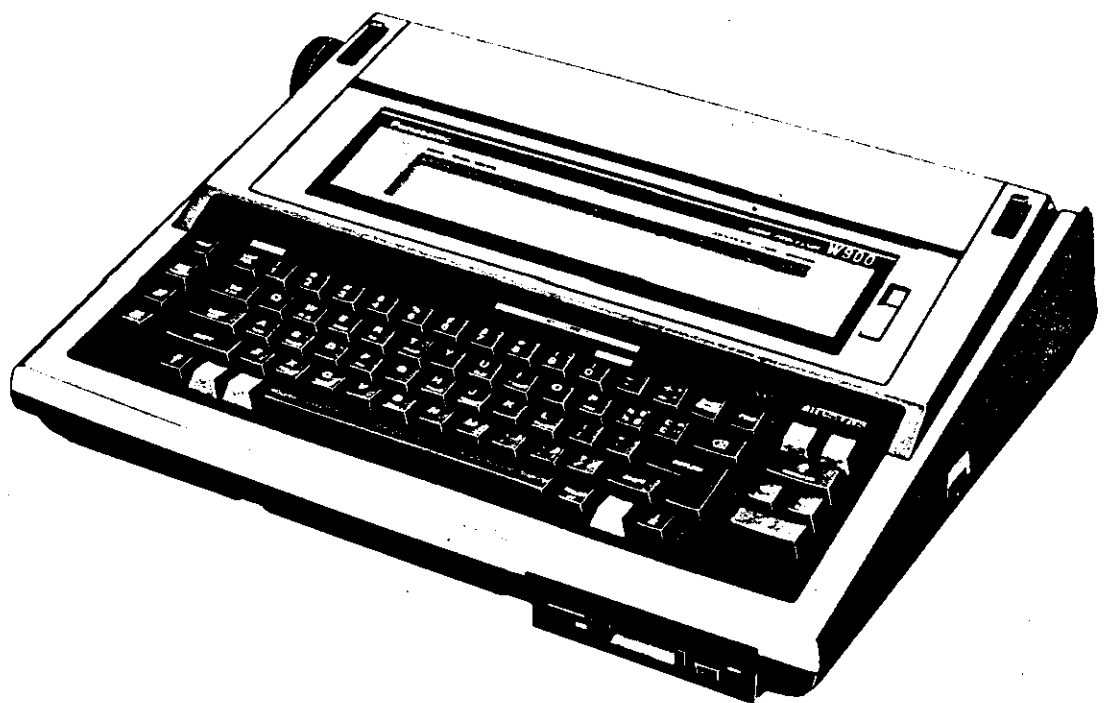

Before operating this unit, please read these instructions completely.

Thank you for your purchase of the Panasonic Word Processor KX-W900.

CAUTION : WHEN YOU OPERATE THIS EQUIPMENT, THE SOCKET OUTLET SHALL BE INSTALLED NEAR THE EQUIPMENT AND SHALL BE EASILY ACCESSIBLE.

WARNING: TO PREVENT FIRE OR SHOCK HAZARD, DO NOT EXPOSE THIS PRODUCT TO RAIN OR ANY TYPE OF MOISTURE.

The serial number of the unit may be found on the label at the right side of the unit when the Paper Support is opened, the LCD is pulled toward you and then the Front Plate is removed. For your convenience, note this number below, and retain this book along with your proof of purchase, to serve as a permanent record of your purchase or for future reference.

MODEL NO. KX-W900
SERIAL NO. _____
NAME OF DEALER _____
DATE OF PURCHASE _____

Accessories (Included)

Make sure that the following parts have been included with the unit.

- | | |
|---|---|
| ● Ribbon Cassette (installed on the carriage) 1 | ● Daisywheel [KX-R10] (installed on the carriage) 1 |
| ● Correction Tape (installed on the carriage) 1 | ● Operating Instruction Manual 1 |
| ● 3.5" Micro-Floppy disk 1 | ● Hard Cover 1 |

Any details given in these Operating Instructions are subject to change without notice.

Precautions

(Be sure to read this section before operating the unit.)

To use the unit, first remove the Hard Cover as shown in the figure.

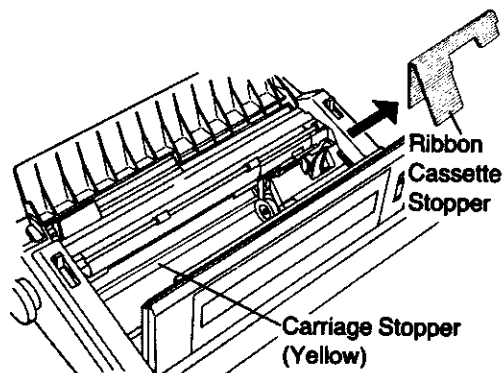
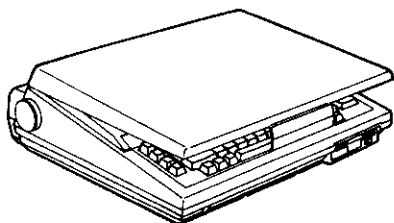

- After confirming that the **POWER** switch is turned OFF, open the paper support and pull the LCD toward you. Remove the front plate by lifting. Then remove the ribbon cassette stopper installed on the ribbon cassette and the carriage stopper installed on the carriage shaft. Be sure to keep these stoppers so the unit can be transported safely, if the need arises.

- When you transport or ship the unit, be sure to position the carriage at the far right of the unit, and insert the carriage stopper and the ribbon cassette stopper.

*If there is a protective film on the LCD cover, remove it so that it does not interfere with the LCD. (Refer to p. 8.)

Cautions

- Do not place your unit where it is exposed to direct sunlight, heat or intense vibration.

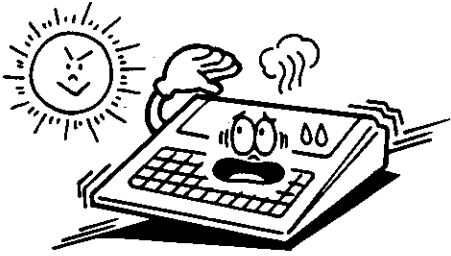

- Do not allow any foreign matter to enter the interior of the unit or get between the keys. Be especially careful of metal objects.

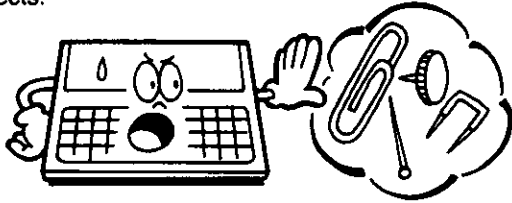

- To prevent electric shock, do not remove screws. No user serviceable parts inside.



- Use only soft, dry cloth to clean your unit. Water or thinners may damage the covers, cases or electronic circuitry.



Handling Disks

- Never touch the magnetic material inside the plastic cartridge.



- Never expose to magnetism (such as found near telephones, loud speakers and common magnets).

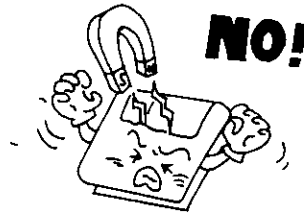

- Never carry your unit with the disk installed.

CONTENTS

Precautions	2		
Cautions	3		
Handling Disks	3		
Chapter 1 BEFORE USING			
1-1 COMPONENT DESCRIPTION.....	8~12	1-7 MICRO-FLOPPY DISK	16
A. Main Parts	8	A. Inserting the Micro-Floppy Disk	16
B. Function Keys	10	B. Protecting a Disk from Erasure	16
C. Names and Operation of the LCD	12	1-8 SETTINGS	17, 18
1-2 POWER SUPPLY	13	A. How to Select the Typing Mode	17
A. Using Household AC Power	13	B. How to Select the Pitch	17
B. Power Switch	13	C. How to Select the Line Spacing	18
1-3 CHANGING THE RIBBON CASSETTE	13	D. How to Select the Keyboard	18
1-4 CHANGING THE CORRECTION TAPE	14	1-9 TYPEWRITER MODE AND WORD	
1-5 CHANGING THE DAISYWHEEL	14	PROCESSOR MODE	19, 20
1-6 INSERTING THE PAPER	15	A. Main Menu	19
		B. Help Key	20
		1-10 USING THE TUTORIAL DISK	21
		A. Tutorial Disk	21
		B. Using the Tutorial Disk	21
Chapter 2 USING THE KX-W900 AS A TYPEWRITER			
2-1 TYPEWRITER MODE	22~36	H. Bold Print	29
A. Procedure for Typing	22	I. Underlining	30
B. Using the Display	22	Continuous Underlining	30
Status Line and Ruler Line	23	Word by Word Underlining	30
Cursor	23	J. Decimal Tabulation	30
Display Messages	23	K. Centering	31
Display Symbols	23	Between Margins	31
C. Margin Formats	24	Between Tab Stops	31
To Clear Margins and Tabs	24	Over a Specified Point	32
To Set Margins and Tabs	24	Auto Half Space	32
D. Hot Zone	25	L. Carriage Return (NORM • AUTO)	33
E. Storing/Changing the Margin Format	25	M. Right Margin Flush	33
F. Index (↓) and Reverse Index (↑)	26	N. Paragraph Indent	34
G. Correction	26	O. Permanent Hyphen	34
To Correct Errors on the Current Line	26	P. Permanent Space	35
To Make Manual Corrections on		Q. Caps Lock	35
a Previous Line	26	R. Micro Spacing	35
Disabling Print When Making		S. Half Space	35
Manual Corrections	27	T. Embedding the Display Symbols	36
To Make Corrections on the Display	28	U. Typing Impression Control	36
To Erase One Word at a Time	29		
To Erase One Line at a Time	29		

Chapter 3 USING THE KX-W900 AS A WORD PROCESSOR

3-1	WORD PROCESSOR MODE	37~39	3-4	APPLICATION	53
	A. Entering the Word Processor Mode	37		A. Stop Code	53
	B. Using the Display	38		To Store a Text with Stop Codes	53
	Status Line and Ruler Line	38		To Print a Text with Stop Codes	53
	Cursor	39			
	Display Messages	39	3-5	ENHANCED TYPING FEATURES	54~59
	Display Symbols	39		A. Bold Print	54
3-2	TEXT MEMORY	40~44		B. Underlining	54
	A. To Create a New Text in Memory	40		Continuous Underlining	54
	Margin Formats	40		Word by Word Underlining	54
	Entering a New Text	41		C. Decimal Tabulation	55
	Over/Insert Typing	41		D. Centering	55
	Layout Display	41		Between Margins	55
	To Disable the Status and Ruler Lines in			Between Tab Stops	56
	Text Mode	42		Over a Specified Point	56
	B. Correction	42		E. Right Margin Flush	56
	To Make Corrections on the Display	42		F. Paragraph Indent	57
	To Erase One Word at a Time	42		G. Permanent Hyphen	58
	To Erase One Line at a Time	43		H. Permanent Space	58
	C. To Continue the Text in Memory	43		I. Caps Lock	58
	D. To Print a Text from Memory	44		J. Micro Spacing	59
	To Stop Printing in the Middle of the Text	44		K. Half Space	59
				L. Embedding the Display Symbols	59
				M. Typing Impression Control	59
3-3	MODIFICATION	45~52			
	A. To Recall a Text for Modification	45			
	B. Scrolling through Text on the Display	45			
	Scrolling to the Next Page	45			
	Scrolling to the Previous Page	45			
	Jumping to a Specific Page	45			
	Scrolling to the Next Display	45			
	Scrolling to the Previous Display	45			
	Scrolling to the Beginning of the Line	46			
	Scrolling to the End of the Line	46			
	C. Word Search	46			
	D. Word Replace	47			
	E. Block Move, Copy and Delete	48			
	To Move a Block of Information	48			
	To Copy a Block of Information	49			
	To Delete a Block of Information	49			
	F. Setting/Changing the Margin Format	50			
	G. Setting Page Length	50			
	H. Changing the Line Spacing within a Text	51			
	I. Page Break	51			
	J. To Clear a Text from Memory	52			
	K. Word-Wrap	52			

1

2

3

4

5

6

7

8

9

10

Chapter 4 MICRO-FLOPPY DISK

4-1 USING THE MICRO-FLOPPY DISK	60~68
A. Formatting the Disk	60
B. Storing a Text to the Disk	61
C. Loading a Text File from the Disk to Memory	62
D. Renaming a File	63

E. Showing the File Names on the Disk	64
Printing a List of the File Names	65
F. Appending a Text	65
G. Copying an Entire Disk	66
H. Deleting a File from the Disk	67

Chapter 5 MAIL MERGE

5-1 MAIL MERGE	69~76
A. Creating a Form Letter	69
Creating a Reference Code	69
B. Creating a Mail List	70
C. Merging a Form Letter and Mail List	71
D. Creating a Qualified Mail List	73

E. Selecting from a Qualified Mail List	73
Wildcards	74
F. Printing Envelopes and Labels	75
Creating a Dummy Text	75
Printing Envelopes and Labels	76

Chapter 6 ADDRESS LIST MEMORY

6-1 ADDRESS LIST MEMORY	77~88
A. To Create Records and Store to the Disk	78
B. To Load an Address List File from the Disk	81
C. To Add to an Existing Address List	82
D. To Sort Records in Alphabetical Order	82
E. To Modify a Record	83
F. Record Search	83

G. To Copy a Record to Another Record	84
H. Printing from the Address List Memory	85
To Print the Address List	85
To Stop Printing in the Middle of the Record	86
I. To Print a Record on an Envelope	86
J. To Delete a Record from Memory	87
K. To Delete All Records from Memory	88

Chapter 7 AUTO COLUMN PLUS

7-1 AUTO COLUMN PLUS	89~98
A. To Create an Auto Column File	90
B. To Calculate in an Auto Column	92
C. To Print an Auto Column	95
D. To Modify an Existing Auto Column	96
E. To Store an Auto Column File to the Disk	96

F. To Load an Auto Column File from the Disk	97
G. To Delete an Auto Column from Memory	98

Chapter 8 THESAURUS

8-1 THESAURUS 99, 100

Chapter 9 ACCU-SPELL PLUS™

9-1 ACCU-SPELL PLUS™
 (Spell Verifying/Correcting Feature) ... 101~108

A. Accu-Spell Plus Operation 102
 Word Endings 103

B. How to Verify/Correct the Spelling of
 an Entire Text 104

C. How to Add Words to
 the User's Dictionary 104

D. How to List Words in the
 User's Dictionary 105
 How to Display the Contents of the
 User's Dictionary 105
 How to Print the Contents of the
 User's Dictionary 106
 How to Exit the List Mode 106

E. How to Store a User's Dictionary File
 to the Disk 106

F. How to Load a User's Dictionary File
 from the Disk 107

G. How to Delete Words from the
 User's Dictionary 108



Chapter 10 APPENDIX

10-1 LIST OF CODE KEY FUNCTIONS 109~111
 A. List of CODE 1 Key Functions 109
 B. List of CODE 2 Key Functions 111

10-2 LIST OF DISPLAY MESSAGES 112, 113

10-3 OTHERS 114
 A. Troubleshooting 114
 B. Product Service 114

10-4 OPTIONAL ACCESSORIES 115

10-5 SPECIFICATIONS 115

10-6 INDEX 116~118

1-1 COMPONENT DESCRIPTION

A Main Parts

Paper Support

Paper Guide
(Refer to page 15.)

Platen

Paper Bail Lever
Pulling this lever toward you moves the paper bail away from the platen to make paper insertion easy.

Paper Bail and Rollers

These are used to hold the paper against the Platen.
Set the rollers according to the width of the paper being used.

Paper Release Lever

This lever is used to release the paper. Pulling this lever toward you releases the paper so that you can adjust it freely. Be sure to move this lever back to engage the paper before typing.

Front Plate

The front plate must be removed when you change the daisywheel, ribbon cassette or correction tape.

LCD Contrast Control
This is used to adjust the contrast of the LCD.

Pitch Scale

Scales for three pitches of 10, 12 and 15 characters per inch are shown. Use these scales for margin and tab setting.

LCD (Liquid Crystal Display)

This unit has a 7-line by 80-character adjustable-angle Liquid Crystal Display (LCD) which helps to confirm the typed characters before printing and is used to edit text. The display can be angled to one of six positions. Open the paper support and then simply grip the display on each side and gently pull it toward you with an upward motion.

Platen Knob

This is used to manually feed the paper up or down. Pushing the platen knob inward disengages the platen clutch so that it can be rotated freely.

Carriage

The ribbon cassette, correction tape and daisywheel are mounted on the carriage.

LCD Cover

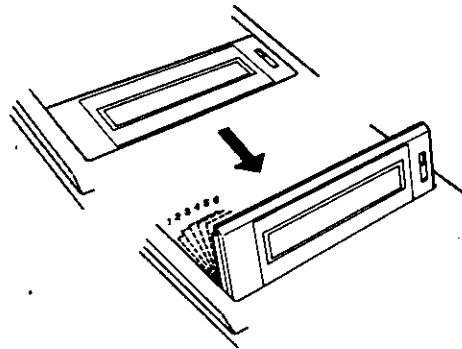

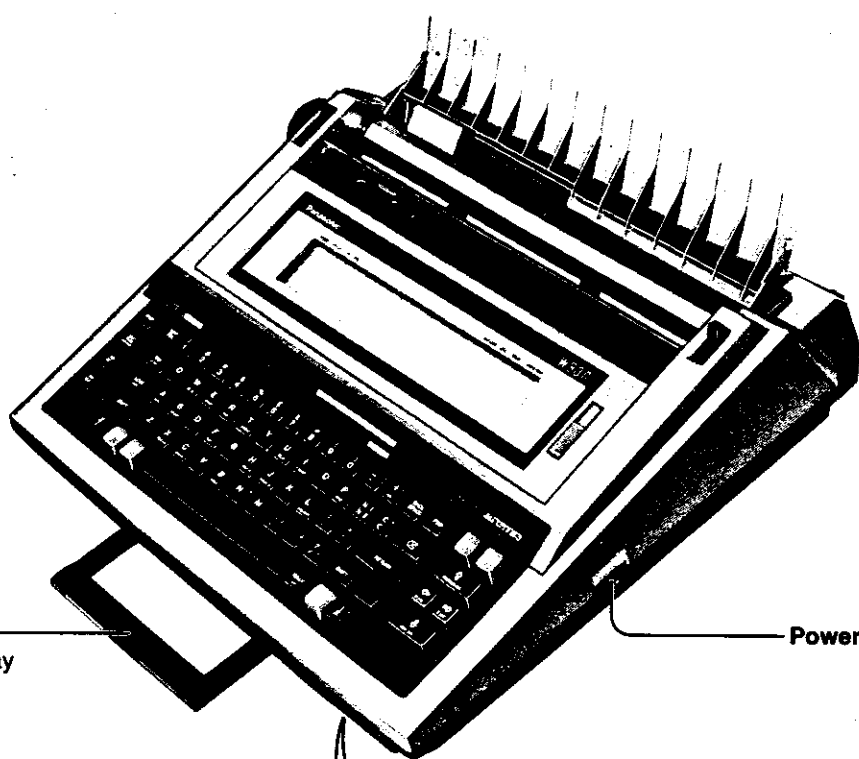

Carrying Handle
Excessive stress may cause the handle to snap off.

Power Switch [POWER ON • OFF]

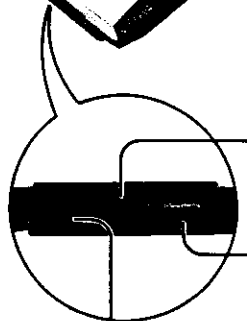

Micro-Floppy Disk Drive
Insert the 3.5" micro-floppy disk into this.

Eject Button
Pushing this button removes the micro-floppy disk from the disk drive.
Never push the eject button while the access indicator is lit.

Access Indicator
This lights when the unit writes or reads information to or from the micro-floppy disk.

AC Power Cord
Compartment Cover
stores AC power cord.

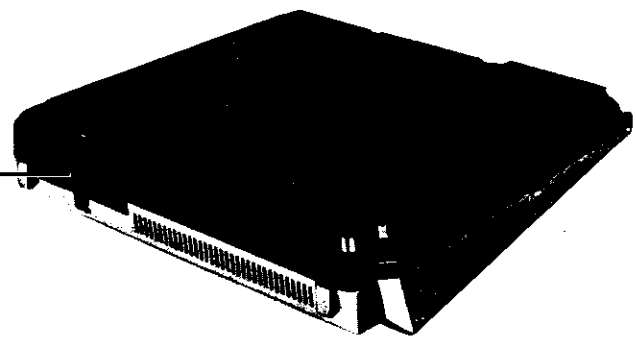

B Function Keys

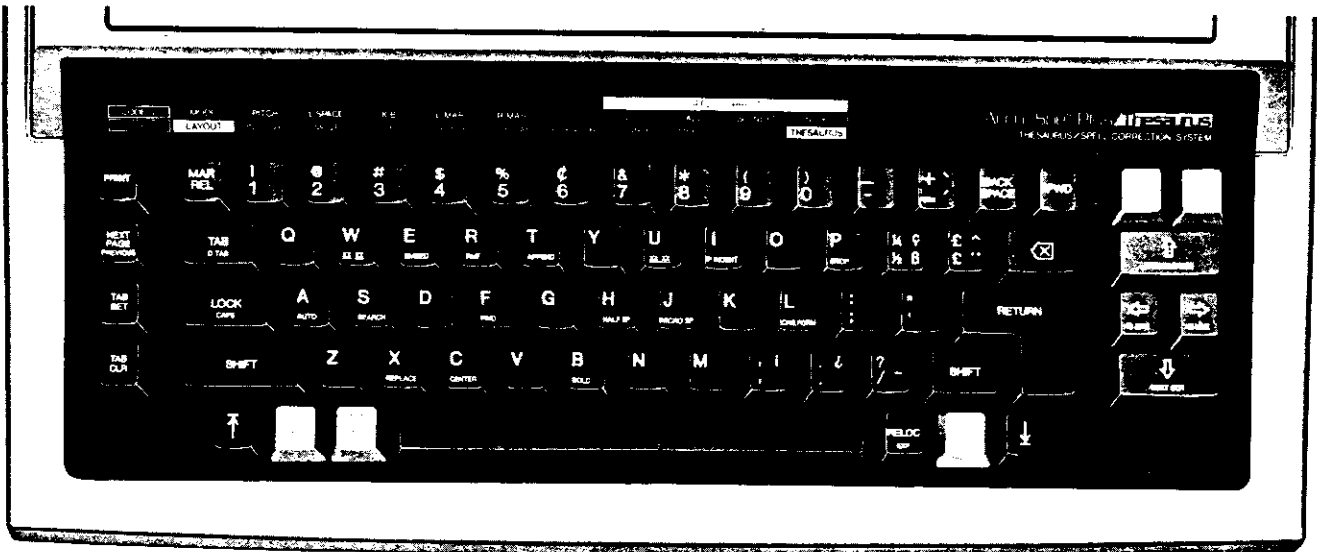

Instructs the unit to start/stop printing documents stored in memory.



Scrolls the display to the next page. Also scrolls the display to the previous page when used with the **CODE 1** key.



Sets TAB stops.



Clears individual TAB stops. Also clears all tabs and margins when used with the **CODE 1** key.



Releases left and right margins.



Moves the carriage/cursor to the next tab stop position or to the right margin.



Pressing down this key creates shift lock so that capital letters or symbols on the top part of keys can be entered successively. Pressing the **SHIFT** key terminates shift lock.



Pressing a character key while holding down this key causes the capital letter or the symbol on the top part of the key to be entered.



Moves the paper down 1/2 line.



Command key for automated functions used in conjunction with other keys.



Command key for automated functions used in conjunction with other keys.



Moves the carriage/cursor one space toward the right.

Repeat function

The asterisk (*) attached to some of the function keys shows that the key has a repeat function.

When the key is kept pressed, its function is repeated until it is released.

All the character keys have a repeat function.

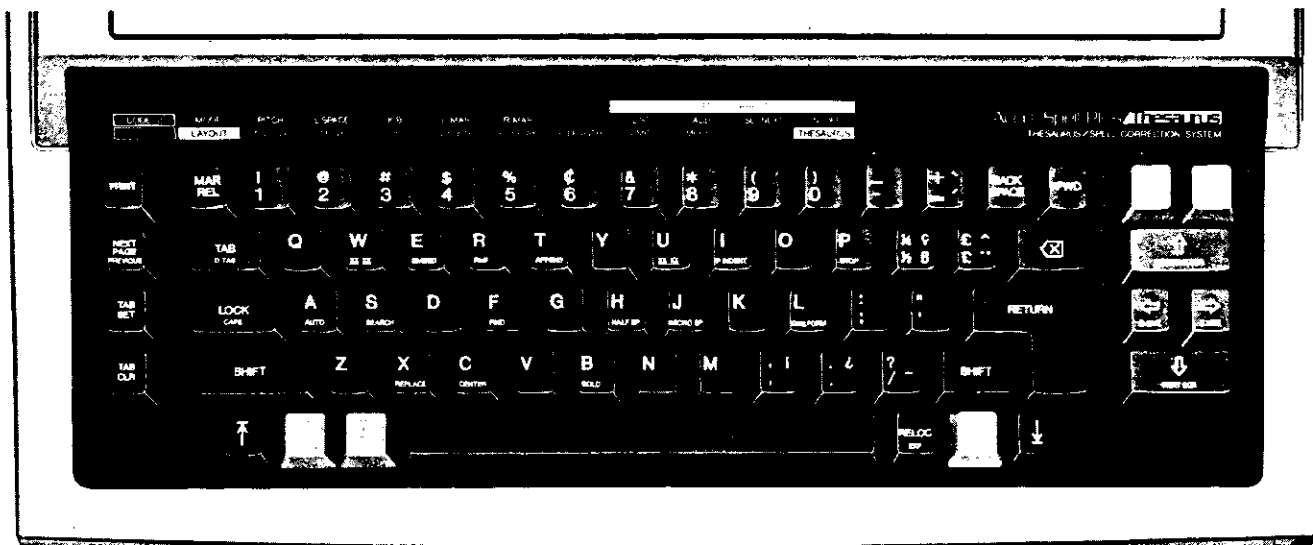

1



* Moves the carriage/cursor one space toward the left.



* Moves the carriage/cursor one space toward the right.



* Deletes characters from paper, display and memory.

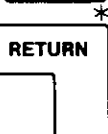

* Moves the carriage/cursor to the left margin of the next line.



Moves the carriage/cursor next to the last character. (When you press this key after correcting errors on a previous line, the carriage/cursor moves next to the last printed character on the end of the lines so that you can continue typing with no delay.)

Moves the carriage/cursor to the beginning of the line without line spacing when used with the **CODE 1** key.



Allows you to delete one word at a time. Also deletes one line at a time when used with the **CODE 1** key.



* Moves the paper up 1/2 line.



Allows you to view the menu contents.



Displays help messages for coded functions.



* Moves the cursor up one line on the display. Also scrolls to the previous display when used with the **CODE 1** key.



* Moves the cursor one space toward the left on the display. Also moves the cursor to the beginning of the line when used with the **CODE 1** key.



* Moves the cursor one space toward the right on the display. Also moves the cursor to the end of the line when used with the **CODE 1** key.

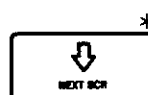

* Moves the cursor down one line on the display. Also scrolls to the next display when used with the **CODE 1** key.

C Names and Operation of the LCD

1

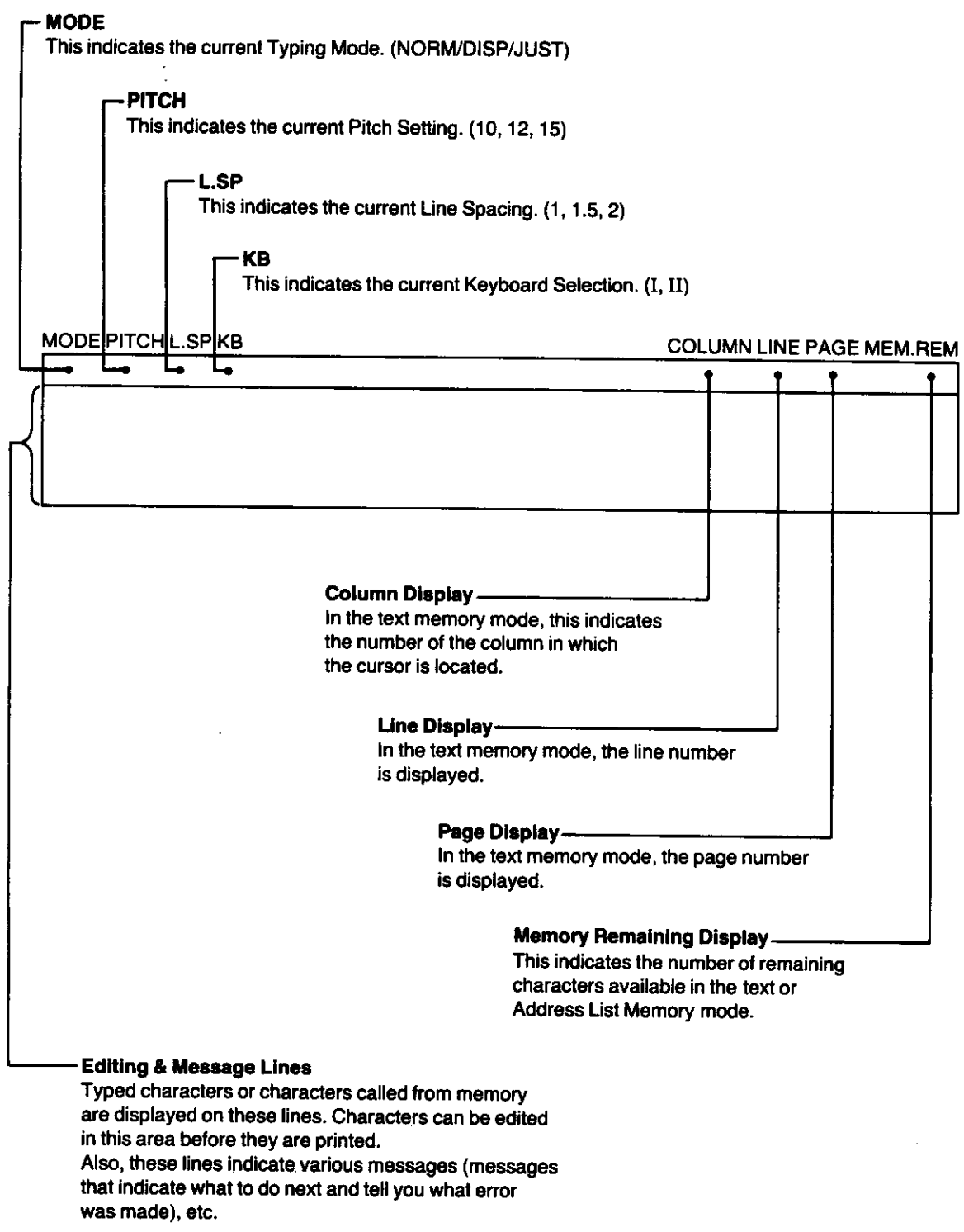

1-2 POWER SUPPLY

A Using Household AC Power

Connect the AC Power Cord to the Power Input Jack on the unit and the household AC Socket.

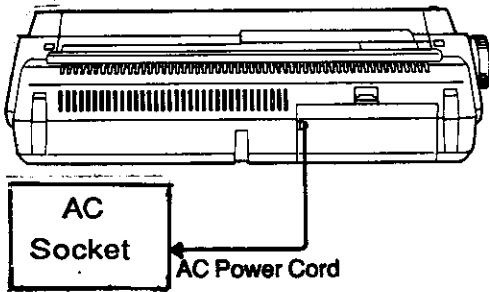

B Power Switch

When the POWER switch is set to "ON", the carriage will move to the far left.

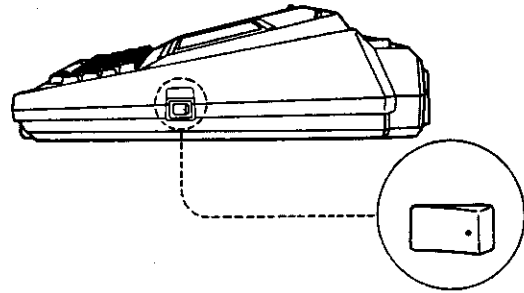

*If you will not be using the unit for several days, unplug the power cord after turning off the POWER switch. About 3 watts are consumed even while the POWER switch is turned off.

1-3 CHANGING THE RIBBON CASSETTE

- 1 Open the paper support and remove the front plate. You will see the carriage, ribbon cassette and daisywheel.

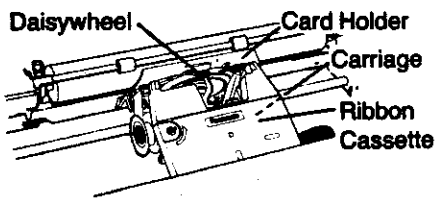

- 2 Hold the ribbon cassette on both sides and lift up the front portion (where the ribbon is exposed) to remove.

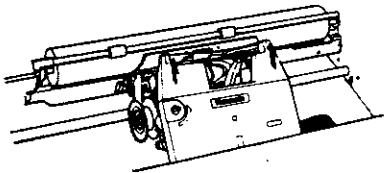

- 3 To insert a new cassette, place the back end of the cassette on the cassette holder on the carriage and snap the front portion of the cassette onto the carriage.

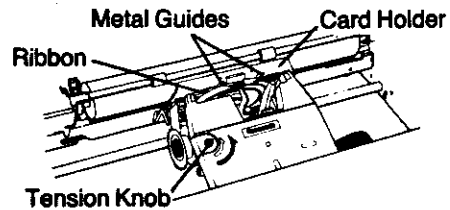

- 4 Advance the tension knob on the cassette counter-clockwise until the ribbon slack is removed.

1-4 CHANGING THE CORRECTION TAPE

- 1 After turning the **POWER** switch off, to replace the correction tape, lift out the typing ribbon cassette (see "1-3 CHANGING THE RIBBON CASSETTE") and remove the two spools of the lift-off tape by pulling them outward.

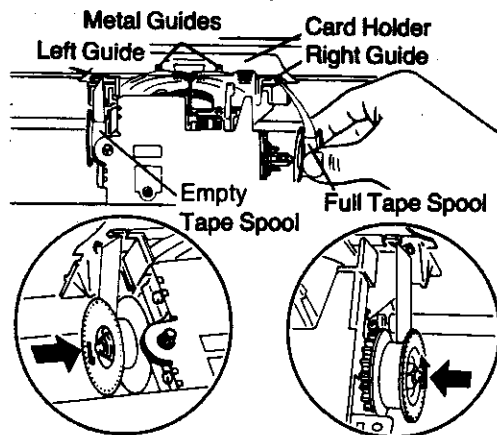
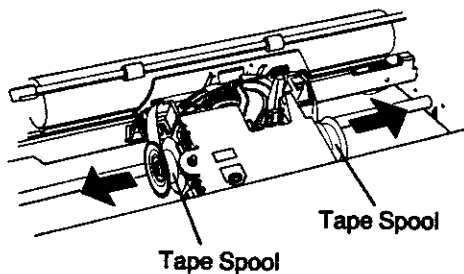

- 2 Place the empty spool of new tape on the left pin so that the tape winds counter-clockwise. Place the tape around the left guide and behind both metal guides. Pull the tape around the right guide and place the loaded spool on the right pin so that the tape unwinds counter-clockwise.

- 3 Manually turn the left-hand spool in the counter-clockwise direction, tightening the tape until resistance is felt.
- 4 Replace the typing ribbon cassette.

*After changing the correction tape, confirm that the correctable (rough) side of the tape faces toward the platen.

1-5 CHANGING THE DAISYWHEEL

You can remove the daisywheel without removing the ribbon cassette.

You will see a green lever on the right side of the carriage. Pull this lever toward you and lift out the plastic cartridge of the daisywheel.

After turning the **POWER** switch off, to insert the daisywheel, place the plastic cartridge in the carriage with the characters facing toward the platen. Push the green lever back into position.

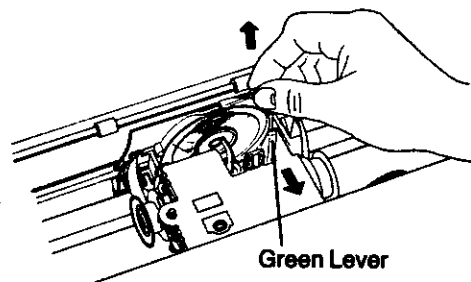

If you experience trouble locking the daisywheel into place, make sure it is pressed down as far as possible. Then, push the locking lever forward again.

1-6 INSERTING THE PAPER

- 1 Open the paper support and position the paper guide for the size of the paper you are using. (The paper guide is located on the paper support and can be moved from side to side.)

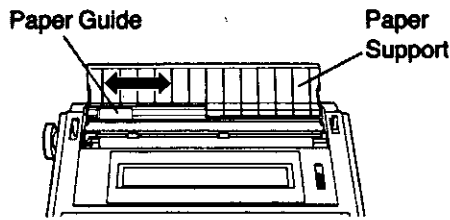

- 2 Insert the paper evenly behind the platen.

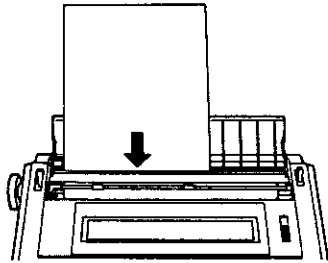

- 3 Pull the paper bail lever towards you. While keeping the left edge of the paper in line with the paper guide, press the **CODE 1+RETURN** keys. Your paper is automatically positioned at line 7. Should you wish to change the point of insertion, using the **RETURN**, **INDEX** or **REVERSE INDEX** keys or turning the platen knob will move the paper to the desired position.

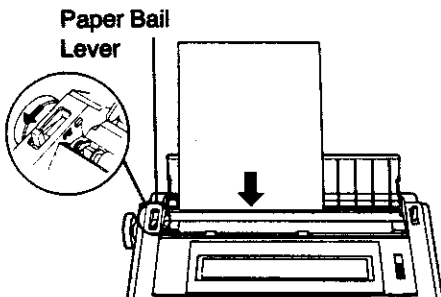

NOTE: If there is any slack in the paper, proper printing and correction will not be possible. Hold the paper by the top edges and pull up to remove any slack. Please do the following.

Pull the paper bail and paper release levers toward you and adjust the paper.

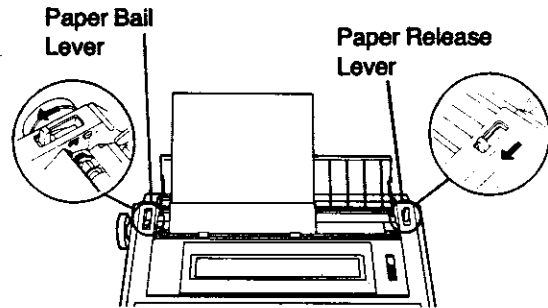

Return the paper release and paper bail levers to their original position.

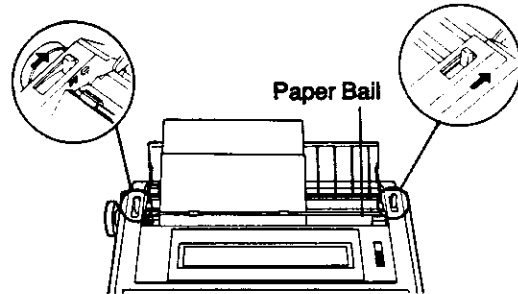

1

1-7 MICRO-FLOPPY DISK

Your unit is equipped with a random access micro-floppy disk drive. This micro-floppy disk drive allows you to use a 3.5-inch 1DD type micro-floppy disk. "1DD" means single-sided, double density and double track. You may store up to 353K per disk. The 353K means approximately 353,000 characters of information.

A Inserting the Micro-Floppy Disk

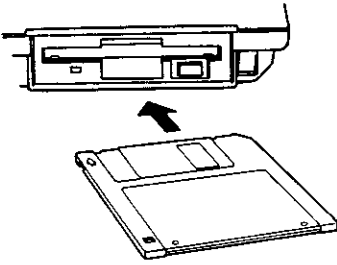

- 1 Insert the disk into the disk drive as shown.
- 2 Gently push the disk until it clicks and the eject button pops out.
- 3 Push the eject button to remove it.

- Never turn the **POWER** switch on or off when the disk is installed in the disk drive.
- Never insert or remove a disk while the access indicator is lit.

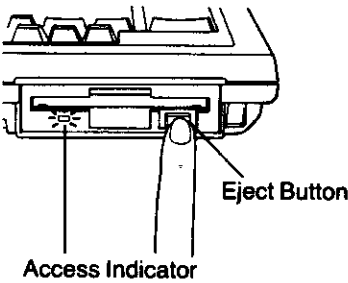

B Protecting a Disk from Erasure

The disk can be protected against accidental erasure. When the disk is protected, you cannot **FORMAT**, **STORE**, **RENAME** or **DELETE** documents. This feature prevents you from "accidentally" erasing or disturbing documents on the disk.

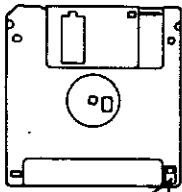

To protect a disk,
slide the button toward the base of the cartridge so that a hole appears.

If you try to store on or format a protected disk, the display will prompt:

Protected disk!

To remove the protection,
slide the button toward the top of the cartridge to close the hole.

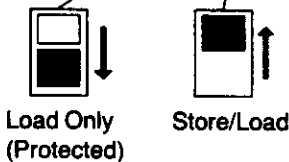

1-8 SETTINGS

A How to Select the Typing Mode

You can choose one of the three typing modes, **NORM**, **DISP** or **JUST**.

Each time the **CODE 2+MAR REL** keys are pressed, one of the three typing modes will alternatively be selected.



The selected mode will appear on the display.

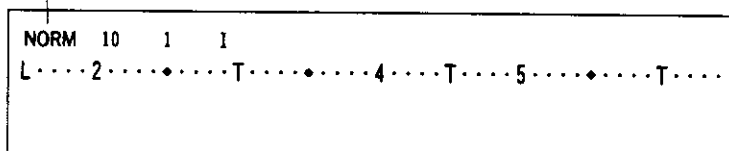

1

Normal (NORM) Typing Mode

The characters entered will be printed immediately. You can set the margins and tabs in this mode and select either **NORM** or **AUTO** carriage return in the Typewriter Mode by pressing the **CODE 1+A** keys.

Display (DISP) Typing Mode

The characters entered will first appear on the display and can be edited (inserted, deleted, corrected) before they are printed. When typing a character after entering a "Hyphen" or "Space" within the "Hot Zone", the carriage automatically returns to the left margin in this mode.

To print a line which does not reach the right margin or "Hot Zone", press the **RETURN** key.

Justify (JUST) Typing Mode

The characters entered will first appear on the display, at which time the characters can be edited before they are printed. When the characters exceed the right margin, the unit will start printing the line up to the last word within the right margin, aligning the last character of each line at the right margin and returning the carriage automatically.

To print a line which does not reach the right margin, press the **RETURN** key.

•In the **Word Processor Mode**, the characters entered will appear on the display in any typing mode (**NORM/DISP/JUST**).

B How to Select the Pitch

You can choose one of the three pitches, "10", "12" or "15".

Each time the **CODE 2+1** keys are pressed, one of the three pitches will be selected.



The selected pitch will appear on the display.

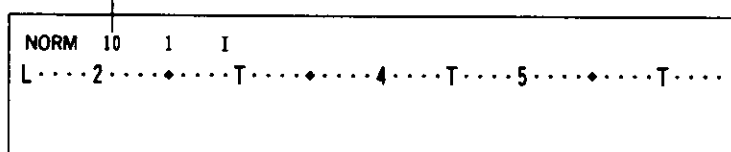

"10" 10 characters per inch (2.54 cm) or 100 characters per line can be printed.

"12" 12 characters per inch (2.54 cm) or 120 characters per line can be printed.

"15" 15 characters per inch (2.54 cm) or 150 characters per line can be printed.

•When changing the pitch, the margin format will be changed corresponding to the current pitch setting.

C How to Select the Line Spacing

You can choose one of three line spacing settings (the amount of paper that is fed each time the **RETURN** key is pressed, which in turn generates a linefeed command), "1", "1.5" or "2".

Each time the **CODE 2+2** keys are pressed, one of the three line spacing settings will be selected.

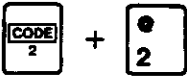

The selected line spacing will appear on the display.

1

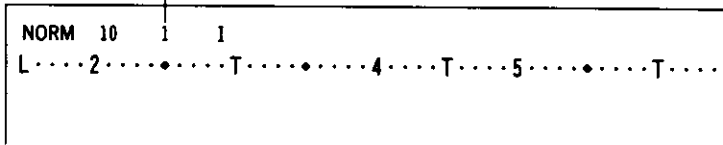

"1" Paper is fed one line for each linefeed command.

"1.5" Paper is fed one and a half lines for each linefeed command.

"2" Paper is fed two lines for each linefeed command.

•When the platen knob is rotated manually, each click moves the platen one half line.

D How to Select the Keyboard

You can choose one of two keyboard settings, "KBI" or "KBII".

Each time the **CODE 2+3** keys are pressed, one of the keyboard settings will be selected.

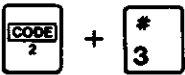

The selected keyboard will appear on the display.

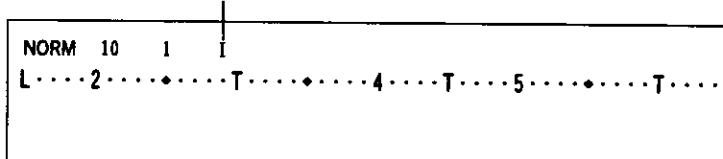

"I" The characters and symbols on the left side of the key can be typed.

"II" The characters and symbols on the right side of the key can be typed.

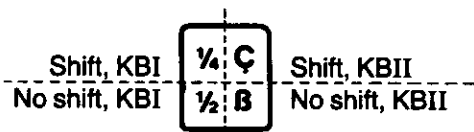

•"Dead" keys

These five accent symbols (´ ˘ ˆ ˜ ˘) can only be used in combination with the characters shown. They will not be printed until the characters, which is to fall below, is pressed.

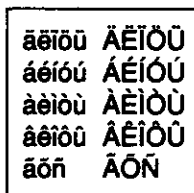

1-9 TYPEWRITER MODE AND WORD PROCESSOR MODE

The unit has two operation modes: Typewriter Mode and Word Processor Mode.

Typewriter Mode

When you turn on the power, the unit is automatically set to the Typewriter Mode. In this mode, you can operate the unit as an electronic typewriter.

Word Processor Mode

The unit automatically stores text created in this mode temporarily in the text memory. This mode allows you to create a new text, to edit it, to store it to the disk, to print it and to use the Mail Merge. Once you begin using the Word Processor Mode, you will find yourself using it all the time because of its useful functions.

Chapter 2 provides instructions for the Typewriter Mode, and Chapter 3 for the Word Processor Mode.

1

A Main Menu

1 Turn on the **POWER** switch.

2  Press the **MENU** key.
You will see the Main Menu on the display.

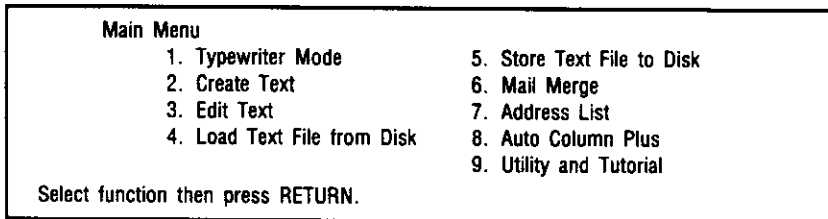

The Main Menu allows you to select the desired function.

1. Typewriter Mode This mode allows you to operate the unit as an electronic typewriter.
2. Create Text Selects the Word Processor Mode. Text created in this mode is stored temporarily in the text memory.
3. Edit Text Allows you to edit the text stored in the text memory.
4. Load Text File from Disk Loads a text file stored on a disk into the text memory.
5. Store Text File to Disk Stores texts created in the text memory to a disk.
6. Mail Merge Allows you to merge a form letter requiring variable information with a mail list.
7. Address List Allows you to store up to 999 separate records in Address List Memory.
8. Auto Column Plus. Allows you to make a ruled table of data and perform basic calculations
9. Utility and Tutorial
 - Deletes or renames a file stored on a disk.
 - Copies a disk to another disk.
 - Formats a disk for first time use or erases all previously stored files.
 - Shows the names of the files stored on a disk.
 - Loads User's Dictionary from a disk or stores it to a disk.
 - Teaches you how to operate the unit.

B Help Key

The **HELP** key has been specifically designed to do just that—HELP you when you cannot remember how to perform a function.

As you continue through this section of the manual, you will learn how to do certain functions and why you are doing them. When at any time, you cannot remember how these steps are performed, the **HELP** key will guide you through.

You may access the **HELP** functions by pressing the **HELP** key.

The **HELP** menu gives all the coded functions and a condensed explanation of what each code represents. This list is alphabetized.

1

Call up to **HELP** Menu to see how it works.



Press the **HELP** key.

Your display will show a list of coded operations.

- For more **HELP**, press the **INDEX** (\downarrow) key. The second display of the **HELP** Menu appears. Pressing the **INDEX** (\downarrow) key repeatedly allows you to move through the **HELP** Menu. To return to the previous display, press the **REVERSE INDEX** (\uparrow) key.
- To return to the first display, press the **CODE 1+RELOC** keys.
- To exit the **HELP** display, press the **HELP** key again.

1-10 USING THE TUTORIAL DISK

A Tutorial Disk

The floppy disk included with your system contains a tutorial program. Operating this tutorial will teach you some of the most popular features of your system. This is a quick and informative way to learn more about your unit.

B Using the Tutorial Disk

- 1 Turn on the **POWER** switch.
- 2 Insert the disk included with your system into the disk drive.

- 3  Press the **MENU** key to display the Main Menu.

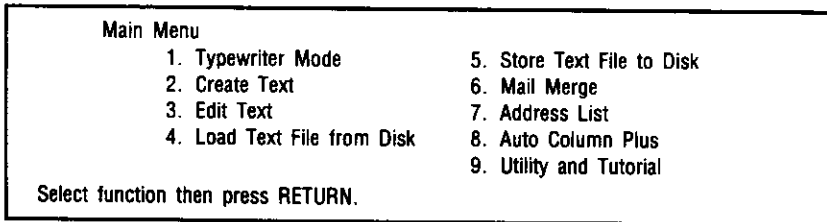

- 4 **ARROW** keys (↑↓←→) Select "Utility and Tutorial" by using the **ARROW** keys or entering "9".



- 5  Press the **RETURN** key.
The display will show the Utility Menu.

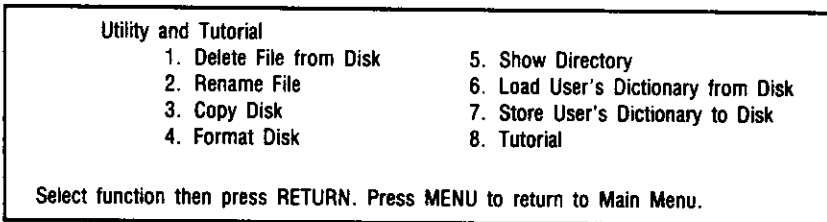

- 6 **ARROW** keys (↑↓←→) Select "Tutorial" by using the **ARROW** keys or entering "8".

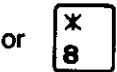

- 7  Press the **RETURN** key.
The display will show the tutorial messages.

- 8 Read the tutorial messages and follow the instructions.

NOTE:

It is not necessary to format the Tutorial Disk. It is already formatted and ready for use. Do not attempt to use the Tutorial Disk in any other machine.

2-1 TYPEWRITER MODE

This section introduces you to the fundamental operations of your Panasonic Word Processor. Read through it and do the exercises to familiarize yourself with each operation.

A Procedure for Typing

- 1 Confirm that the ribbon cassette, correction tape and daisywheel are properly installed on the carriage.
 - Remove the ribbon cassette stopper and the carriage stopper if you have not already done so.
- 2 Turn on the **POWER** switch.

Whenever you turn on the power, the unit is automatically set to the Typewriter Mode. Each time the **POWER** switch is turned on, the last margin format you used will be initialized and the carriage moves to the far left. The display shows the number of characters available on the writing line, the typing mode, the pitch, the line space, the keyboard, etc. on the status line.

 - Confirm that the pitch setting corresponds with the pitch of the daisywheel you are using. (Refer to p. 17.)
- 3 Insert the paper using the automatic paper inserting function.

(Refer to p. 15.)
Now you can begin typing.
- 4 Type the following characters.
 - When the typing mode is set to "NORM", the characters will be printed on the paper immediately.
 - When the typing mode is set to "DISP" or "JUST", the characters will appear on the display. Press the **RETURN** key to print them, at the same time the characters on the display will disappear.
 - The characters will be printed on the paper as shown.

Typewriter

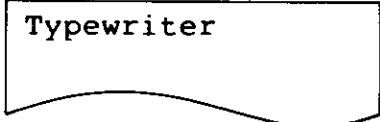

Typewriter

You will now learn how to use the unit to perform simple operations. Read the following descriptions thoroughly in order to make the most of the functions of the unit.

When you want to return to the Typewriter Mode from a different mode, press the **MENU** key. You will see the Main Menu on the display. Select "Typewriter Mode" by using the **ARROW** keys or entering "1" and press the **RETURN** key.

B Using the Display

The unit has a 7-Line by 80-Character adjustable-angle LCD which acts as an operator prompt, allowing you to correct, edit, move or delete information.

When typing, most errors are "felt" by the operator. Through the use of the display, you can check if there are errors and correct them before they are printed.

In order to activate the display, select the "DISP" or "JUST" typing mode.

In the Typewriter Mode, just one line on the display is used for typing.

Status Line and Ruler Line

The display shown below appears a few seconds after you turn on the power or set the unit to the Typewriter Mode.

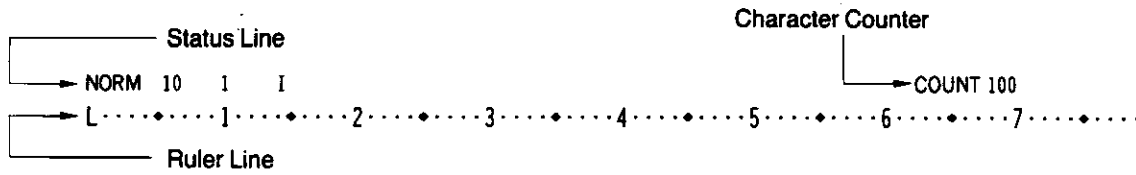

At the top of the display, you will see the status line and the ruler line. When using your unit as a typewriter, you will see a character counter at the top right corner of the display. This counter tells you how many characters are on the writing line and how many remain as you type information. Also, you will see the typing mode, pitch, line space and keyboard setting on the status line.

Beneath the status line, you will see the dotted ruler line. This line indicates the current margin and tab settings, and the beginning of the "Hot Zone".

- L: Left margin
- R: Right margin
- T: Tab stop position
- H: Beginning of the Hot Zone
- H_T: Hot Zone & Tab Stop

Every tenth space is represented by the number on the ruler line and a diamond (◆) represents every fifth space.

Cursor

When working with the display, you will see a flashing symbol which is called the cursor. This lets you know where you are at all times regardless of your typing mode.

Display Messages

The display will give you certain messages to guide you through your typing projects. As you proceed through the exercises in this manual, these messages will become second nature to you. At the back of the book (Chapter 10), you will find a listing of all the display messages offered to you on your unit.

Display Symbols

As you begin the exercises, you will see various symbols on the display. These symbols indicate certain functions and are listed here to help you understand what you are seeing.

You are not expected to memorize these symbols. As you proceed through this book, you will become familiar with them and understand how they relate to the various functions you are asking your unit to perform.

Display Symbols (Typewriter Mode)

▶ ◀	BOLD Mode Start/End	≡	Paragraph Indent
▶ ◀	Continuous Underline Mode Start/End	--	Half Space
▶ ◀	Word by Word Underline Mode Start/End	---	Micro Space
↓	Index Command	—	Permanent Space
↑	Reverse Index Command	=	Temporary Hyphen

C Margin Formats

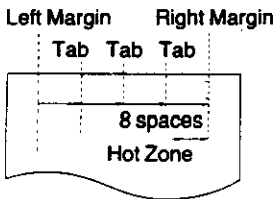

When you turn off the **POWER** switch, the margin formats (margins and tabs) which were previously stored will be cleared.

Each time you turn on the **POWER** switch, set the margin formats according to the following procedure.

To Clear Margins and Tabs

The unit allows you to clear all tabs and margins at one time.



Press the **RETURN** key.

The carriage/cursor must be at the left margin to begin making changes to the margin format.



Press the **CODE 1+TAB CLR** keys.

The carriage moves to the far left and clears the entire line format (both margins and all tabs).

To Set Margins and Tabs



Clear the current margin format.

Refer to "To Clear Margins and Tabs".



Press the **SPACE BAR** to move the carriage/cursor to the desired left margin position.



Press the **CODE 2+4** keys to set the left margin. You will see the letter "L" on the ruler line representing the left margin.



Press the **SPACE BAR** until you reach the first desired TAB stop.



Press the **TAB SET** key to set the first TAB stop.

You will see the letter "T" on the ruler line representing the TAB stop. If necessary, press the **TAB CLR** key to clear a previous or incorrect TAB stop.

6 Repeat steps 4 and 5 for each desired TAB stop.

Remember that the maximum number of TAB stops is 28.

If you have entered more than 28 tab stops, the display will show:

Too many tab stops!



Press the **SPACE BAR** to move the carriage/cursor to the desired right margin position.



Press the **CODE 2+5** keys to set the right margin. You will see the letter "R" on the ruler line representing the right margin.



Press the **RETURN** key to move the carriage to the left margin on the next line and the cursor to the left margin on the same line.

- When a TAB stop is set at the beginning of the Hot Zone, the position is indicated by "T" on the Ruler Line.

- At least 11 spaces are required between the right and left margins.

For the first exercise, set up the following:

- Left margin at 15
- 1st TAB at 30 •2nd TAB at 45 •3rd TAB at 60
- Right margin at 75

Your display will show the number of characters available on the writing line. In this case, "COUNT 60" will be displayed on the status line.

D Hot Zone

The "Hot Zone" represents the number of spaces between the bell and the last character at the right margin. When the carriage/cursor enters the "Hot Zone", you will hear the bell which indicates that the right margin is approaching. The beginning of "Hot Zone" is represented by an "H" on the ruler line. The "Hot Zone" is preprogrammed in the machine at 8 spaces from the right margin. (Refer to "To Set Margins and Tabs" on p. 24.)

E Storing/Changing the Margin Format

The unit allows you to store/change margin formats by using the **CODE 1+L** keys.

Two different margin formats can be temporarily stored in the memory of the unit. You can name these formats Y or Z. To store/change either of the margin formats perform the following.

- 1 Set up a margin format. (Refer to p. 24.)
Now you are going to store this format in memory.

- 2  +  Press the **CODE 1+L** keys.

Store current margin format to Y / Z ?

- 3  Press the **Y** key.
These margin and tab settings are now stored in memory.

- 4  +  Press **CODE 1+TAB CLR** keys to set up the second format (refer to "To Set Margins and Tabs" on p. 24) and store it in margin format Z.

- Left margin at 11
- 1st TAB at 20 •2nd TAB at 33
- 3rd TAB at 45 •4th TAB at 54
- Right margin at 64

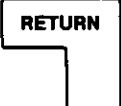
- 5  Press the **RETURN** key.

- 6  +  Press the **CODE 1+L** keys.

Store current margin format to Y / Z ?

- 7  Press the **Z** key.
 - In the future, this margin format may be recalled at any time by pressing **CODE 1+Y** or **CODE 1+Z**. This eliminates the need to reset margin and tab settings. **REMEMBER, CODE 1+L** is only used when **STORING** margin formats.
 - When you want to change any of the stored margin formats, simply set new margins and tabs and store over the previous format by pressing **CODE 1+L** and selecting **Y** or **Z**.

Note:

The stored formats Y or Z will be cleared from the memory when the **POWER** switch is turned off.

2

F Index (↓) and Reverse Index (↑)

The **INDEX (↓)** key allows you to move the paper ½ line toward the bottom of the page. The **REVERSE INDEX (↑)** key allows you to move the paper ½ line toward the top of the page.

These keys are used for the typing of superscripts (e.g. 10³) and subscripts (e.g. log₁₀ 1000). You will also use them during correction.

The 4th of July is Independence Day.

1 To type this sentence, you would first enter "The 4".

2



Press the **REVERSE INDEX (↑)** key and type "th".

3



Press the **INDEX (↓)** key to reposition the carriage on the actual typing line.

4 Continue typing.

To type subscripts, reverse the keystroke order.

G Correction

To Correct Errors on the Current Line

The unit has a one line correction memory so that you can delete the characters on the current line automatically with one simple operation.

To erase the last printed character on the current line;

1



Press the **CANCEL (X)** key to "lift" the incorrect character off the paper. If you press the **CANCEL (X)** key again, the next character will be erased.

• To erase characters towards the beginning of the line, press the **CODE 1+RELOC** keys, and then the **SPACE BAR** or the **BACKSPACE** key to position the carriage so that the character to be erased is aligned between the two vertical lines on the top of the clear plastic card scale.

Press the **CANCEL (X)** key.

2 Type the correct character(s).

3



Press the **RELOC** key after making the correction to move the carriage/cursor back to the end of the line.

To Make Manual Corrections on a Previous Line

In the Typewriter Mode, if you have typed several lines and notice an error in one of the preceding lines, you may instruct the unit to perform manual correction.

To erase characters on previous lines:

1



+



Press the **CODE 1+CANCEL (X)** keys.





The message "Manual Correction Mode" will appear on the display.

This instructs the unit to enter the manual correction mode. The carriage/cursor will automatically move to the left margin to allow you to begin making corrections.

2













Press the **REVERSE INDEX (↑)** key to position the carriage on the line with the error.

- 3 Position the carriage over the error. Press the **SPACE BAR**, **TAB**, **CODE 1+J** (Micro Spacing), **CODE 1+H** (Half Spacing) or **BACKSPACE** key.
- 4  +  Press the **CODE 1+CANCEL** () keys.
- 5 Retype the incorrect character. This will lift the character off the paper.
- 6 Type the correct character. If the typing mode is set to "DISP" or "JUST", press the **PRINT** or **RETURN** key.
 - Repeat steps 2-6 to correct errors on another line.
 - Repeat steps 3-6 to correct another character on the same line.
- 7  Press the **RELOC** key. This will position the carriage to the end of the last line.
 - The message "Manual Correction Mode" will disappear from the display.

Disabling Print When Making Manual Corrections

The **PRINT** key may be used to make manual corrections. This feature is especially helpful when correcting in the justify printing mode or making many corrections successively.

- 1  +  Press the **CODE 1+CANCEL** () keys. The carriage/cursor will automatically return to the left margin.
- 2  Press the **REVERSE INDEX** () key to position the carriage at the beginning of the line on which the correction is to be made.
- 3  Press the **PRINT** key. The message "No Print Mode" will appear on the display.
- 4 Position the carriage over the error. Press the **SPACE BAR**, **TAB**, **CODE 1+J**, **CODE 1+H** or **BACKSPACE** key.
- 5 Retype the error. This information has now been entered back into memory but has not reprinted on the paper.
- 6  Press the **PRINT** key. The message "No Print Mode" will disappear from the display.
- 7  Press the **CANCEL** () key to delete the entered characters.
- 8 Type the correct character.
 - When the typing mode is set to "DISP", press the **PRINT** key to print characters.
 - Repeat steps 2-8 for each error to be corrected.
- 9  Press the **RELOC** key. This will position the carriage/cursor to the right of the last character printed before correction.

In the justify printing mode:

- Perform steps 1-2.
- Press the **PRINT** key.
- Retype the entire line with the error, and continue typing the line until the carriage reaches the right margin. It is necessary to type beyond the error line so that the unit can perform its justification.
- Press the **BACKSPACE** key or **SPACE BAR** to position the carriage on the error.
- Press the **CANCEL (X)** key to delete the error.
- Type the correct characters.
- Press the **PRINT** or **RETURN** key.

To Make Corrections on the Display

2

With the typing mode set to "DISP" or "JUST", each character typed will appear on the display. When typing, most errors are "felt" by the operator. Through the use of the display, you can see the error and correct it before it is printed on paper.

Select the "DISP" or "JUST" typing mode.

As you type, the character counter will count down for each character key pressed, letting you know how many characters are remaining available on the current line.

Enter the following information including the errors. Do not press the RETURN key at the end of the line.

"Errors are corrected before tehy are printed on paper."

- 1  Press the **BACKSPACE** key to position the cursor one character to the right of the error.

Errors are corrected before teh are printed on paper.

- 2  Press the **CANCEL (X)** key to delete the incorrect characters.

Errors are corrected before ty are printed on paper.

- 3 Enter the correct characters.



Errors are corrected before they are printed on paper.

- 4  Press the **FWD** key to move the cursor toward the next error or to the end of the line.

- 5  Press the **RETURN** key to print the information you have typed.
- If the error is located toward the beginning of the line, you may use the **CODE 1+ RELOC** keys instead of the **BACKSPACE** key. To reposition the cursor at the end of the line, you may use the **RELOC** key instead of the **FWD** key.

To Erase One Word at a Time





The **QUICK ERASE** key may be used to speed up correction by deleting one word on the paper or the display at a time. The carriage/cursor must be on the space immediately following the word to be deleted. The Quick Erase operation is available within the correction memory.

-  /  Press the **BACKSPACE** key or **SPACE BAR** to position the carriage/cursor one character to the right of the incorrect word.
 - In the "DISP" or "JUST" mode, you may use the FWD key instead of the "SPACE BAR".
 - If you have pressed the **SPACE BAR** after typing an incorrect word, make sure to press the **BACKSPACE** key before pressing the **QUICK ERASE** key.
-  Press the **QUICK ERASE** key.
- 3 Retype the correct word.

2

To Erase One Line at a Time







This function may be used to speed up correction by deleting one entire line on the page or the display at once.

-  /  Press the **BACKSPACE** key or the **SPACE BAR** to locate the last character of the line to be deleted.
 - In the "DISP" or "JUST" mode, you may use the FWD key instead of the "SPACE BAR".
-  +  Press the **CODE 1+QUICK ERASE** keys. The unit will delete an entire line at a time.
 - If you want to stop deleting information in the middle of the line, press the **PRINT** key. ("NORM" mode only.)
The display will show:

Continue printing?
Yes-RETURN / No-
- 3 Retype new information.

H Bold Print

You can instruct the unit to "highlight" certain words or characters for emphasis by using the bold print function.

-  +  Press the **CODE 1+B** keys. The display message "**BOLD**" appears on the status line.
- 2 Type the characters. They will be printed in bold face.
- 3  +  Press the **CODE 1+B** keys again to cancel the command.
 - When the typing mode is set to "DISP" or "JUST", the symbol "  " is displayed before and the symbol "  " is displayed after the characters to be bold.

I Underlining

You can instruct the unit to "underline" certain words or characters for emphasis by using the underlining function.

Continuous Underlining



Press the **CODE 1+U** keys.
The display message "XX XX" appears on the status line.

2 Type your information.

All characters and spaces will be underlined.



Press the **CODE 1+U** keys again to cancel the command.

•When the typing mode is set to "DISP" or "JUST", the symbol "▶" is displayed before and the symbol "◀" is displayed after the characters to be underlined.

Word by Word Underlining



Press the **CODE 1+W** keys.
The display message "XX XX" appears on the status line.

2 Type your information.

Only characters will be underlined.
•Spaces will not be underlined.



Press the **CODE 1+W** keys again to cancel the command.

•When the typing mode is set to "DISP" or "JUST", the symbol "▶" is displayed before and the symbol "◀" is displayed after the characters to be underlined.

J Decimal Tabulation

You may use the **CODE 1+TAB** keys in place of the **TAB** key when typing statistical formats. The unit will automatically align decimal points at the preset tab stops and eliminates the need to space to the correct starting position in a column.

This function also can be used when typing formats which include characters.

1 Recall the **CODE 1+Y** format which stored in memory. (Refer to p. 25.)

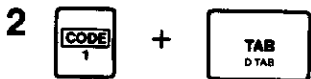

Press the **CODE 1+TAB** keys.
The carriage/cursor will move to the first tab position and the display will show the "DECTAB" message on the status line.

3 Enter the numbers and decimal point.

The entry can be seen on the display.

```
NORM 10 1 I DECTAB
L.....2.....T.....4.....T.....5.....T.....
123.64■
```

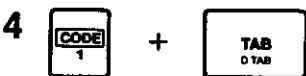

Press the **CODE 1+TAB** keys.

The first column will be printed so that the decimal point is positioned on the first tab stop and the carriage/cursor will move to the next tab position.

5 Repeat the above steps to complete all of your column entries.

•After entering the last number, press the **RETURN**, **TAB** or **PRINT** key to execute printing.
•To cancel the decimal tabulation command, when "DECTAB" is on the status line as shown in steps 2 and 3, press the **CANCEL** (⊗) key.

K Centering

The unit has four ways to center information; between margins, between tab stops, over a specified point and auto half space.

Between Margins



Press the **RETURN** key to position the carriage/cursor at the left margin.



Press the **CODE 1+C** keys to move the carriage/cursor to the center of the margins. The display will show the "CENTER" message on the status line.

3 Enter the information to be centered.

The characters will appear on the display.

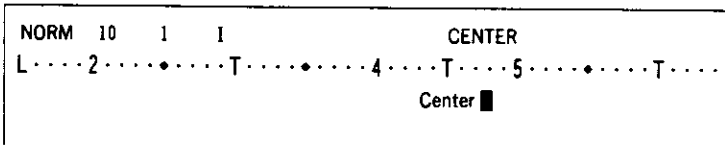

Press the **RETURN, TAB** or **PRINT** key.

The information entered will be printed between the margins* and the centering command will be cancelled.



*When the indent function is in operation, centering is performed between the indented position and the right margin.

Between Tab Stops



Press the **TAB** key to position the carriage/cursor at the left side tab position of the column you want to center in.



Press the **CODE 1+C** keys to move the carriage/cursor to the center of the tab stops.

3 Enter the information to be centered.

The characters will appear on the display.

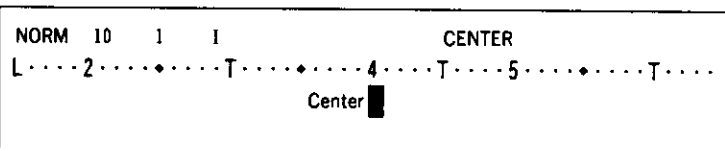

Press the **RETURN, TAB** or **PRINT** key.



The information entered will be printed between the tab stops and the centering command will be cancelled.



2

Over a Specified Point

1  Press the **SPACE BAR** to move the carriage/cursor to the desired position.

2  +  Press the **CODE 1+C** keys.
Enter the information to be centered. The characters will appear on the display.

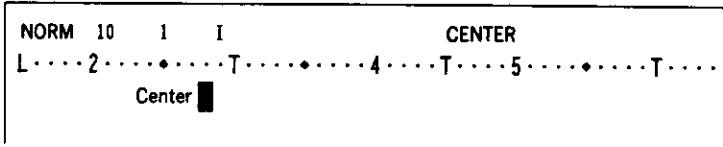

2

3  Press the **RETURN, TAB** or **PRINT** key.
The information entered will be printed and the centering command will be cancelled.



OR



Auto Half Space

You can automatically correct a word within the correction memory with one that has one character more or any amount of characters less than the original word.



1 Locate the carriage/cursor on the error.

2  /  Press the **CANCEL (X)** or **QUICK ERASE** key to delete the incorrect characters in the current line.

3  +  Press the **CODE 1+C** keys to activate the auto half space.



4 Type the correct characters.

5  /  Press the **PRINT** or **RETURN** key.
The characters entered will be printed.

L Carriage Return (NORM - AUTO)



The **CODE 1+A** keys select when a carriage return operation is performed.

NORM Printing stops at the right margin.
Carriage return must be pressed manually.

AUTO When typing a character after entering a "Hyphen" or "Space" within the "Hot Zone", the carriage/cursor automatically returns to the left margin or the paragraph indent position of the next line.

- When the automatic carriage return mode is set, the display message "AUTO" appears on the status line.
 - To reset to manual carriage return mode, press the **CODE 1+A** keys again.
 - NORM** is selected when the unit is powered on.
 - You can select "NORM" or "AUTO" carriage return only when the typing mode is set to "NORM".
- In the "DISP" or "JUST" mode, the automatic carriage return is always active.

2

M Right Margin Flush

This command instructs the unit to print the information with the last character of each line aligned at the right margin. You can use this function to conveniently type dates or addresses.



Press the **CODE 1+R** keys to move the carriage/cursor to the right margin. The display will show "R.M.F." on the status line.

2 Enter the information. The information will be shown on the display.

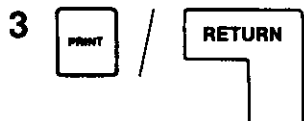
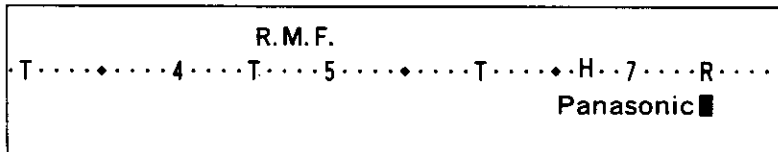

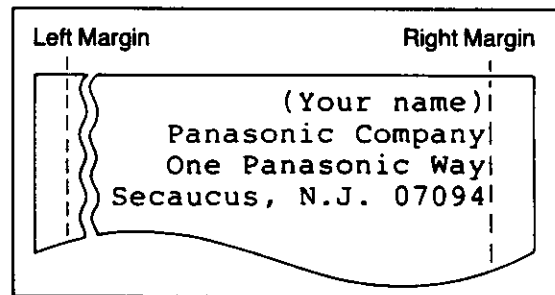

Press the **PRINT** or **RETURN** key. The characters will be printed with the last character right margin flush. The command will then be cancelled.



N Paragraph Indent

This command provides you with the ability to set a temporary left margin and eliminates the need to position the carriage/cursor to an indented location on every line.

1  /  Press the **TAB** key or the **SPACE BAR** to move the carriage/cursor to the desired indented position.

2  +  Press the **CODE 1+I** keys.
This sets the indented (temporary left margin) position.
The display message "INDENT" appears on the status line and the display symbol "¶" on the ruler line indicates the indent position.

2

```
NORM 10 1 I INDENT
L.....2·¶.....T.....4.....T.....5.....T.....
```

3 Type the characters.





Press the **RETURN** key to move the carriage/cursor to the indented position on the next line.
Continue typing.

4  + 

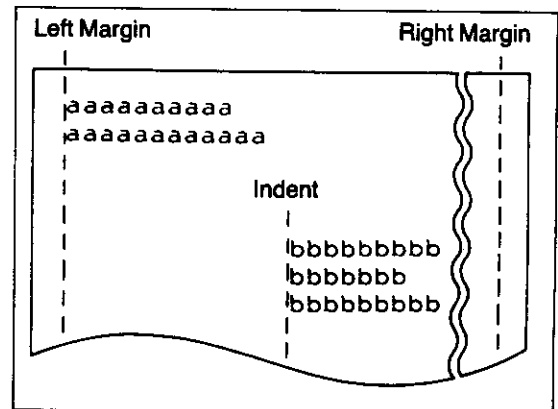
Press the **CODE 1+I** keys again to cancel the command.
The carriage/cursor will move to the original left margin when the **RETURN** key is pressed.



O Permanent Hyphen

 + 

If you press the **CODE 1+HYPHEN (-)** keys within the "Hot Zone", when automatic carriage return is activated, the unit will continue printing without generating an automatic return. This coded hyphen is called a "Permanent Hyphen". It is indicated by the symbol "-" on the display and will be printed at the same point every time you print this text.

When you reach the end of a line, you may need to hyphenate a word to stay within your margin settings. In this case, press the "-" key and enter the next character. The hyphen will be printed and the carriage/cursor will automatically returns to the left margin of the next line. This hyphen which is used temporarily in the "Hot Zone", is called a "Temporary Hyphen". It is indicated by the symbol "-" on the display. If you change the margin setting, the hyphen will not be printed unless it falls within the "Hot Zone".

P Permanent Space

Since your unit allows you to print with automatic returns or with a justified margin, there may be times you do not want to separate characters or words. The unit allows you to set a "Permanent Space" between characters and will not separate them when printing with variable line lengths.

1 Type the first word.

New █

2  +  Press the **CODE 1** key+**SPACE BAR**.

New █

3 Type the second word.

New York █

When the characters are printed, the unit will recognize the two words as one and will not separate them.



2

Q Caps Lock

To set the unit for typing capital letters, lower case numbers, punctuation marks and symbols:

Press the **CODE 1+LOCK** keys.

In this mode, the **SHIFT** key will call for opposite characters to be entered.

1  +  Press the **CODE 1+LOCK** keys.
The caps lock mode is activated and the display message "CP.LOCK" appears on the status line.

2 Type the text.

3  +  Press the **CODE 1+LOCK** keys again to cancel the command.

R Micro Spacing

 + 

Pressing the **CODE 1+J** keys moves the carriage by $\frac{1}{60}$ inch.
You may use this function to "squeeze" characters together.
In the "DISP" and "JUST" mode, the symbol "..." will appear on the display.

S Half Space

 + 

Pressing the **CODE 1+H** keys reduces the normal carriage spacing by one half. In the "DISP" and "JUST" mode, the symbol "--" will appear on the display.

T Embedding the Display Symbols

While working with the display, symbols appear for the various commands you have instructed the unit to perform. As a result, your text will shift one character to the right for each display symbol. Many times it is difficult to visualize how your text will look with these symbols on the display.

To embed or "hide" these symbols:



Press the **CODE 1+E** keys.

Your text will appear without the symbols and you will be able to see your text as it will print.

To show the display symbols:



Press the **CODE 1+E** keys again.

U Typing Impression Control

This controls the impact of the printed characters. Select one of the three typing impression levels that is most suited for your needs.



Press the **CODE 1+8** keys to change the typing impression level.
The following line appears at the bottom of the display.

Impression : Light Medium Heavy

You can select one of three typing impression levels: "Light", "Medium" or "Heavy". Select the desired impression level by using the **ARROW** keys and press the **RETURN** key.

- "Light" is softer than "Heavy".
- At first, try "Light" and if you feel the impression level is too soft, try "Medium" or "Heavy".
- Each time the **POWER** switch is turned on, the impression level is reset to "Light".

3-1 WORD PROCESSOR MODE

A Entering the Word Processor Mode

1 Turn on the **POWER** switch.

2  Press the **MENU** key to display the Main Menu.

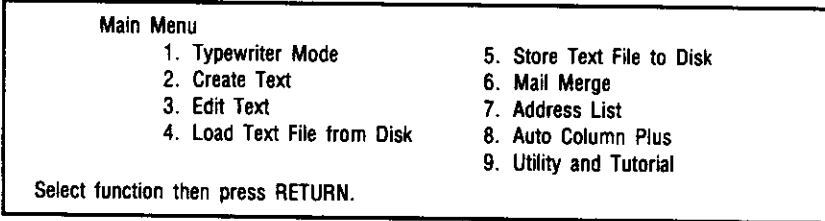

3 **ARROW** keys (↑↓←→) Select "Create Text" by using the **ARROW** keys or entering "2".

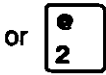

4  Press the **RETURN** key.

This instructs the unit to enter the Word Processor Mode.

• If a file already exists in the memory, the following message will appear on the display.

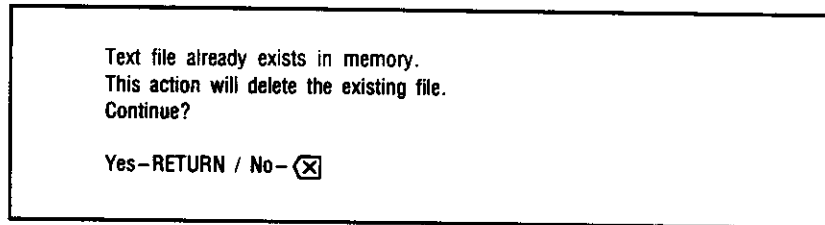

To delete the existing file and create a new text, press the **RETURN** key.

To retain the existing file in memory, press the **CANCEL** () key and the Main Menu will reappear.

5  To close your text, press the **MENU** key.

The display will show the Main Menu and your text will be stored temporarily in the text memory.

NOTE:

All information stored in the memory is cleared when the **POWER** switch is turned **Off**. For permanent storage, texts created in the Word Processor Mode must be stored on the micro-floppy disk.

B Using the Display

The unit has a 7-Line by 80-Character adjustable-angle LCD which acts as an operator prompt, allowing you to correct, edit, move or delete information.

When typing, most errors are "felt" by the operator. Through the use of the display, you can check if there are errors and correct them before they are printed.

Status Line and Ruler Line

The display shown below appears in the Word Processor Mode. All text creating and editing is done on this display.

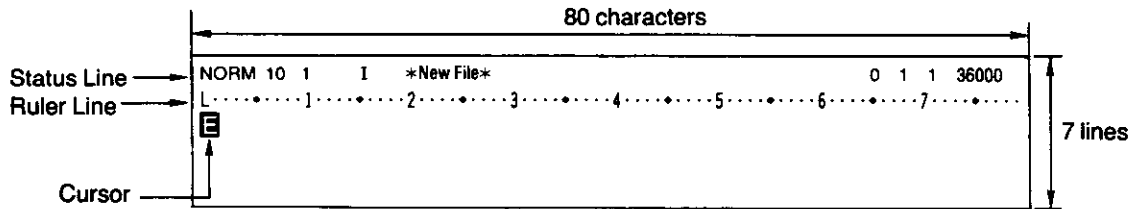

Status Line

At the top of the display, you will see the status line and ruler line. When in the Word Processor Mode, the status line tells you what column, line, and page your cursor is on within the text, and the number of characters available in the memory. Also, you will see the typing mode, pitch, line space, and keyboard setting, the same as in the Typewriter Mode.

New File Indicates you are in the Word Processor Mode.

0 (COLUMN) Indicates which column of the current line the cursor is in.

1 (LINE) Indicates which line of the current page the cursor is on.

1 (PAGE) Indicates which page of the text the cursor is on.

36000 (MEM. REM) Indicates the number of characters available in the memory.

• The status line will also indicate the name of the document you are currently working with.

Ruler Line

Beneath the status line, you will see the dotted ruler line, which indicates the margin and tab setting, and the beginning of the "Hot Zone".

L: Left margin

R: Right margin

T: Tab stop position

H: Beginning of the Hot Zone

H_T: Hot Zone & Tab stop

Every tenth space is represented by the number on the ruler line and a diamond (◆) represents every fifth space.

Cursor

When working in the Word Processor Mode, you will see a flashing symbol which is called the cursor. This lets you know where you are at all times.

“**E**” is a display symbol which indicates the end of the text.

Display Messages

The display will give you certain messages to guide you through your typing projects. As you proceed through the exercises in this manual, these messages will become second nature to you. At the back of the book (Chapter 10), you will find a listing of all the display messages offered to you on your unit.

Display Symbols

As you begin the exercises, you will see various symbols on the display. These symbols indicate certain functions and are listed here to help you understand what you are seeing.

You are not expected to memorize these symbols. As you proceed through this book, you will become familiar with them and understand how they relate to the various functions you are asking your unit to perform.

Display Symbols (Word Processor Mode)

3

↵	Manual Return	⇧	Tab Command
▣ ▣	BOLD Mode Start/End	--	Half Space
▶ ◀	Continuous Underline Mode Start/End	---	Micro Space
▶ ◀	Word by Word Underline Mode Start/End	—	Permanent Space
▣	Centering	=	Temporary Hyphen
D	Decimal Tabulation	1̄, 15̄, 2̄	Line Spacing
R	Right Margin Flush	0̄, Ȳ, Z̄	Margin Format
S	Stop Code	V̄	Mail Merge Variable
↓	Index Command	T̄	Mail Merge Record Header
↑	Reverse Index Command	E	End of Text
≡	Paragraph Indent	◀	Page Break

3-2 TEXT MEMORY

The text memory allows you to perform some of the more sophisticated text editing functions you would find on high-priced word processing systems.

The unit has an internal memory of 36K (approx. 36,000 characters). The disk drive provides unlimited storage on 3.5" micro-floppy disks.

"Text Memory" is used for documents, letters, projects requiring editing, or projects requiring repetitive printing. Text which is created in the Word Processor Mode is stored temporarily in the text memory.

If your text reaches the maximum storage capacity about 36,000 characters, the bottom of the display will prompt:

Memory full!

At this time you will be required to store the text to a floppy disk to continue with your current project. All of this will be covered in Chapter 4.

With this memory you may temporarily store documents that are either short or lengthy. Once you begin using the Word Processor Mode, you will find yourself using it all the time because of its ease of operation and the perfect finished appearance of your projects.

3

A To Create a New Text in Memory

Margin Formats

Before creating a new text, set the margins and tabs as an original format of your text.

1 Enter the Word Processor Mode. (Refer to "Entering the Word Processor Mode" on p. 37.)

2  +  Press the **CODE 1+L** keys.

Change margin format, Y / Z / O (original) ?

3  Press the "**O**" key to store the original format.



4  +  Press the **CODE 1+TAB CLR** keys to clear the margins and all tabs.

5 Set the margins and tabs. Position the cursor by using the **LEFT** and **RIGHT ARROW** keys or **FWD** and **BACKSPACE** keys then set the margins or tabs by using the **CODE 2+4**, **CODE 2+5** or **TAB SET** keys.

6  Press the **RETURN** key.

This current format is stored as an original margin format for your text. You can easily change this format referring to "Setting/Changing the Margin Format" on p. 50.

Entering a New Text

- 1  Press the **MENU** key.
Enter the Word Processor Mode and set the original format of your text.
Now you can begin entering a new text.
- 2 Enter the information to be stored.
- 3  When finished, press the **MENU** key again to store the information and close the text.
●When closing your text, do not turn off the power.

Over/Insert Typing

When creating a text in the Word Processor Mode, you can choose either the over typing mode or the insert mode.



Each time the **CODE 1+1** keys are pressed, insert/overtyping will alternately be selected.

- In the over typing mode, no display message will appear on the status line and you can type new characters over existing text to replace it at the cursor position.
- In the insert mode, the display message "INS." will appear on the status line. With insert on, you may insert additional characters at the cursor position by simply typing the additional characters or words. Your text will shift to the right as each character is entered, automatically reformatting the text to conform with the margins on the display.

3

Layout Display

In the Word Processor Mode, the **CODE 1+MAR REL** keys function will display the layout of the page on the display in reduced form.

The actual characters will not be displayed but an image of how the text will be printed is displayed. This is convenient for checking and correcting the layout of the text before it is printed.

While creating or editing the text,

- 1  +  Press the **CODE 1+MAR REL** keys.

- 2 The display will show the layout of the text according to your current settings.
(A maximum of 52 lines.)

For example:

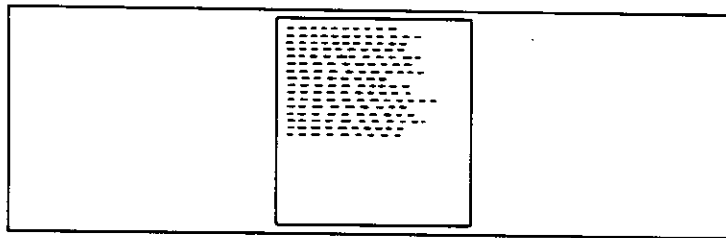

- You may change the typing mode, pitch, and/or line spacing and view the results.
- The current left and right margin and page length settings will also be displayed.

- 3  +  Press the **CODE 1+MAR REL** keys.
Your text will reappear on the display.

To Disable the Status and Ruler Lines in Text Mode

To disable the status and ruler lines (in text mode):

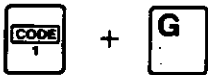

Press the **CODE 1+G** keys.

Your text will display without the status and ruler lines and other information, and you will be able to use all of the lines on the display for editing text.

To display the status and ruler lines:



Press the **CODE 1+G** keys again.

[other information]

- Text Name
- Typing Mode
- Pitch
- Line
- Memory Remain
- Line Spacing
- Keyboard Indication
- Column
- Page
- etc.

3 B Correction

To Make Corrections on the Display

- 1 **ARROW** keys (↑↓←→) or **BACKSPACE** or **FWD** key. Position the cursor one character to the right of the error by using the **ARROW** keys, **BACKSPACE** or **FWD** key.



- 2  Press the **CANCEL** (☒) key to delete the incorrect character.

- 3 Enter the correct character.

•This way of making corrections is only applicable to the insert typing mode. In the over typing mode, position the cursor over the error and enter the correct character.

To Erase One Word at a Time

The **QUICK ERASE** key may be used to speed up correction by deleting one word at a time.

- 1 **ARROW** keys (↑↓←→) or **BACKSPACE** or **FWD** key. Position the cursor one character to the right of the incorrect word by using the **ARROW** keys, **BACKSPACE** or **FWD** key.





•If you have pressed the **SPACE BAR** after typing an incorrect word, make sure to press the **LEFT ARROW** or **BACKSPACE** key before pressing the **QUICK ERASE** key.

- 2  Press the **QUICK ERASE** key.

- 3 Retype the correct word. •In the over typing mode, retype from the error to the end of the line.

To Erase One Line at a Time

This function may be used to speed up correction by deleting one entire line at a time.

- 1** **ARROW** keys (↑↓←→) or  Position the cursor to one character to the right of the last character of the line to be deleted by using the **ARROW** keys or **FWD** key.
 - If the cursor is located toward the beginning of the line, you may use the **CODE 1+RIGHT ARROW** keys.
- 2**  +  Press the **CODE 1+QUICK ERASE** keys.
- 3** Retype new information.



C To Continue the Text in Memory

If you are interrupted while entering a text, simply end the document and continue it later.

- 1**  Press the **MENU** key.

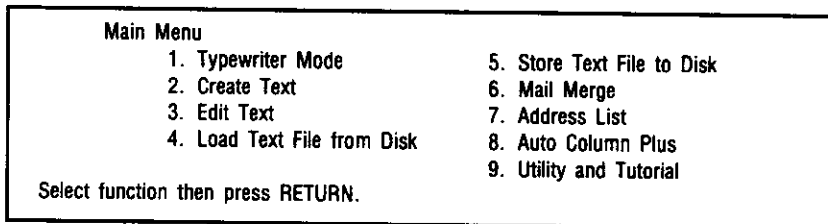
3



- 2** **ARROW** keys (↑↓←→) or  Select "Edit Text" by using the **ARROW** keys or entering "**3**".
- 3**  Press the **RETURN** key.

Your text will appear on the display and the cursor will be located at the beginning of the text.
- 4** Continue the text.
 - You may use the **RELOC** key to position the cursor at the end of the text.
- 5**  Press the **MENU** key again to store the added information and close the text.
 - Be sure to save your text on disk if you are going to turn off the **POWER** switch.

D To Print a Text from Memory

Now you have entered your text into memory and want to print it.
Before printing the text, you must recall it on the display.

- 1  Press the **PRINT** key.
The display will show the printing parameters.

Text Print	
Print from page : 1	
to page : 1	(L:Last Page)
Page Numbering : N	(1,2...start number)
	(N:no numbering)
Print Impression : 1	(1-Light/2-Medium/3-Heavy)
Set parameters then press RETURN. Press PRINT to display text.	
Left Margin = 0	
Right Margin = 100	
Page Length = 54	

- 2  If all of the printing parameters are correct, press the **RETURN** key to start printing.
If not, select the desired parameter by using the **ARROW** keys, and change it.

- You can select which pages to print (maximum of 999), the page numbering (maximum of 9999) and the printing impression level.
- Number(s) of page(s) to print start on the page number on which the cursor is located.

When printing is completed, your text will appear on the display.

You can also confirm the current left/right margin and page length settings at the right side of the display.

- When printing multiple pages, at the end of each page the display will show:



Page end!
Continue?
Yes-RETURN / No- <input checked="" type="checkbox"/>

Insert a new sheet of paper and press the **RETURN** key to continue or press the **CANCEL** () key to stop printing.

To Stop Printing in the Middle of the Text





- 1  Press the **PRINT** key during printing.

Continue printing?
Yes-RETURN / No- <input checked="" type="checkbox"/>

- 2  or  If you want to exit the printing mode:
Press the **CANCEL** () key.
If you want to continue printing the text:
Press the **RETURN** key.



3-3 MODIFICATION

A To Recall a Text for Modification

-  Press the **MENU** key.
- ARROW keys (↑↓←→) Select "Edit Text".
or 
-  Press the **RETURN** key.
Your text will appear on the display.
You are now ready for modification.
-  Press the **MENU** key again to store the modified information and close the text.

B Scrolling through Text on the Display

In addition to the **ARROW** keys, you may scroll quickly by using the following keys.

 +  Pressing the **CODE 1+FWD** keys allows you to scroll forward word by word.



 +  Pressing the **CODE 1+BACKSPACE** keys allows you to scroll backward word by word.

3

Scrolling to the Next Page

 Press the **NEXT PAGE** key.
The display will show the next page and the cursor will move to the beginning of the page.

Scrolling to the Previous Page

 +  Press the **CODE 1+NEXT PAGE** keys.
The display will show the previous page and the cursor will move to the beginning of the page.

Jumping to a Specific Page



-  +  Press the **CODE 1+7** keys.

Page Number =



- Enter the desired page number.

-  Press the **RETURN** key.
The display will show the desired page.

Scrolling to the Next Display

 +  Press the **CODE 1+DOWN ARROW** keys.
You will see the next display.

Scrolling to the Previous Display

 +  Press the **CODE 1+UP ARROW** keys.
You will see the previous display.

Scrolling to the Beginning of the Line



Press the **CODE 1+LEFT ARROW** keys.
The cursor will move to the beginning of the line.

Scrolling to the End of the Line



Press the **CODE 1+RIGHT ARROW** keys.
The cursor will move to the end of the line.

C Word Search

This feature allows you to quickly advance to a specific point without scrolling through your text. Any word, string of characters or commands that appear within the text can be searched.

The characters entered in the search command must be typed exactly as they appear in the text; otherwise, the search will not be located.

3

The **CODE 1+S** function will search through the text from the current cursor position to the end of the text.

- 1 Recall the text from memory.

- 2  Press the **CODE 1+S** keys.

Search Word = █

- 3 Enter the word or words (maximum of 30 characters) you are searching for.

- 4  Press the **RETURN** key.
The cursor will be positioned at the end of the word(s) to be located.

- 5 Move the cursor to the desired position, and modify.

- 6  To locate a second occurrence of the entered word within the text, press the **CODE 1+INDEX (↓)** keys.

If you have passed the word location you are looking for and want to go backwards through the text, press the **CODE 1+REVERSE INDEX (↑)** keys.

•When the entered word is not included in the text, the display will show:

Not found!

- To search for a return mark, press the **CODE 1+RETURN** keys.
- To search for a start mark of the **BOLD** or **UNDERLINE** functions, press the **CODE 1+B** keys for **BOLD** or **CODE 1+U** or **CODE 1+W** keys for **UNDERLINE**.
- To search for an end mark of the **BOLD** or **UNDERLINE** functions, press the **CODE 1+B** keys twice for **BOLD** or **CODE 1+U** or **CODE 1+W** keys twice for **UNDERLINE**.

D Word Replace

There may be times when certain words (such as titles or names) appear very often in a document, and need to be changed. The unit can replace the words individually or globally wherever they appear in the text.

The **CODE 1+X** function will search and replace through the text from the cursor position to the end of the text.

1 Recall the text from memory.

2  +  Press the **CODE 1+X** keys.

Current Word = █

3 Enter the word or words to be replaced. Do not exceed 30 characters.

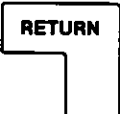
 Press the **RETURN** key.

Replace Word = █

4 Enter the word or words to be inserted. Do not exceed 30 characters.

5  Press the **RETURN** key.
The cursor will be positioned at the first occurrence of the word to be replaced.

Do you want to change this word?

RETURN-Replace / N-Next word / G-Global change / -Exit

6  Press the **RETURN** key to replace the word or words and locate the next occurrence of the replaced word.

 • Press the "N" key to skip this occurrence and locate the next occurrence of the replace word.

 • Press the "G" key to replace the word or words globally.

 • Press the **CANCEL** () key to cancel this command.

If the entered word is not in the text, the display will show the following and the word replace command will be cancelled.

Not found!

- To enter the start code for the **BOLD** or **UNDERLINE** function, press the **CODE 1+B**, the **CODE 1+U** or **CODE 1+W** keys respectively.
- To enter the end code for the **BOLD** or **UNDERLINE** function, press the **CODE 1+B** keys twice, the **CODE 1+U** or **CODE 1+W** keys twice respectively.

Only a word or words, with the following symbols in front of and behind, can be searched for.

- SPACE, CODE 1+H, CODE 1+SPACE BAR, CODE 1+J
- UNDERLINE
- TAB
- DECIMAL TABULATION
- BOLD, UNDERLINE MARK
- PARAGRAPH INDENT
- CENTERING
- RIGHT MARGIN FLUSH
- RETURN
- STOP CODE

3 E Block Move, Copy and Delete

When the need to move, copy or delete a sentence or a paragraph arises, the unit can do it simply and automatically.

To Move a Block of Information

- 1 Recall your text from memory.



Press the **CODE 1+2** keys.

- 3 Position the cursor at the beginning of the block to be moved.



Press the **RETURN** key.

- 4 Position the cursor at the end of the block to be moved.



Press the **RETURN** key.

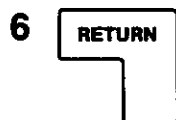

- 5 Move to the position where you want to move the block which you have just marked.



Press the **RETURN** key to move the block to the new position.

- You can always cancel this command by pressing the **CANCEL (⊗)** key.

To Copy a Block of Information

1  +  Press the **CODE 1+3** keys.

2 Position the cursor at the beginning of the block to be copied.



Press the **RETURN** key.

3 Position the cursor at the end of the block to be copied.





Press the **RETURN** key.

4 Move to the position where you want to copy the block which you have just marked.



Press the **RETURN** key to copy the block at the new position.

To Delete a Block of Information

1  +  Press the **CODE 1+4** keys.

2 Position the cursor at the beginning of the block to be deleted.



Press the **RETURN** key.

3 Position the cursor at the end of the block to be deleted.



Press the **RETURN** key to delete the block.

F Setting/Changing the Margin Format

When a new text is created, 3 margin formats are stored with it. The "Y" and "Z" formats are stored as well as the current margin format which is stored as "O" (original margin format). To change to one of the stored margin formats perform the following.

1 Recall your text.

2  +  Press the **CODE 1+L** keys.

Change margin format, Y / Z / O (original) ?

3  //  //  Press the "Y", "Z" or "O" key.

4  or 
 or  Set the desired margin and tab settings on the ruler line by using the **ARROW** keys or **FWD** key and **BACKSPACE** key.

5  Press the **RETURN** key.

6  +  To recall the stored margin format, press the **CODE 1+O**, **CODE 1+Y** or **CODE 1+Z** keys with the cursor positioned at the beginning of the line.

If you attempt to recall at any other position, the display will show:

Cannot set here!

G Setting Page Length

The **CODE 1+6** command sets the page length of the text.

Page length is pre-programmed at a standard 54 lines per page.

Page length is memorized in each text.

When the number of lines on the page exceeds the programmed page length, the unit will automatically end the page and start a new one.

To set the page length:

1  +  Press the **CODE 1+6** keys.

Page Length = 54

2 Type the desired number of lines per page (maximum of 99).

3  Press the **RETURN** key.

H Changing the Line Spacing within a Text

Before printing a text, you must set the line spacing. Your document will print with the line spacing that you have selected. However, there may be occasions when you will need to change the line spacing at a specific point within a text. You may instruct the unit to change the line spacing while inside a text and this will be stored with the document. This feature is available only at the beginning of a line.

To change the line spacing:

- 1  +  Press the **CODE 1+K** keys with the cursor positioned at the new line spacing position.

Line Space : 1.0 1.5 2.0

- 2  /  Select the desired line spacing using the **ARROW** keys.

- 3  Press the **RETURN** key.

At the cursor position, you will see a symbol on the display ($\bar{1}$, $\bar{15}$ or $\bar{2}$) indicating the line spacing you selected.

This feature may also be used to store a line space command at the beginning of a document. This eliminates the need to set the line spacing selection before printing.

NOTE: Although this command is stored in the text, you will not see the effect on display. Upon printing the document, the selected line spacing will be executed at the point the command was given.

3

I Page Break

The unit allows you to insert a page break code in the text so that you may break the text into separate pages.



- 1 Move the cursor to the position where you want to break the page.

- 2  +  Press the **CODE 1+5** keys.
The display symbol "☛" will appear on the display.

Also, a row of dashes will appear across the display indicating a page break.



J To Clear a Text from Memory

When you need to enter a new text, you can delete an old text from memory as follows:

- 1  Press the **MENU** key.
- 2 **ARROW** keys (↑↓←→) or  Select "Create Text".
- 3  Press the **RETURN** key.
The following display will appear:

Text file already exists in memory.
This action will delete the existing file.
Continue?

Yes-RETURN / No-

- 4  Press the **RETURN** key to delete the text in memory.
• If you do not wish to delete the text, press the **CANCEL** () key.

K Word-Wrap

Word-wrap means that a word exceeding the right margin will be shifted automatically to the beginning of the next line.

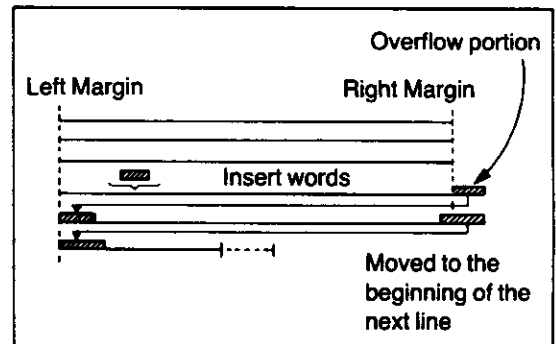

This function starts from the space before the last word which would overflow the right margin. After the insertion of a new word, the last word will be moved to the beginning of the next line. Word-wrap will occur within the sentences of each paragraph.

EXAMPLE:

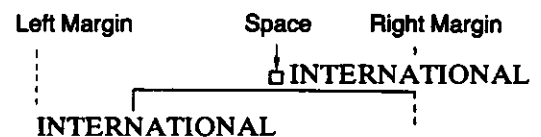

• Spaces which fall at the left margin after carriage return with word-wrap will be eliminated and printing of the recorded characters will start at the left margin.

3-4 APPLICATION

A Stop Code

You may want to type a letter and send it to several different people. Each letter can be personalized and have specific but different information inserted into the body of the text.

These different bits of information are referred to as "variables".

This feature will allow you to enter a text and instruct it to stop printing at a particular point so that you may insert the variable within the body of the letter.

This code "to stop printing and insert variables" is called a stop code.

To Store a Text with Stop Codes

To activate the insert command you must be entering a text in memory.

1 Perform the steps of "To Create a New Text in Memory" on p. 40.

2 Begin typing the document.

3  + 

When you are at the position within the text where you want to insert variable information,

Press the **CODE 1+P** keys.

The symbol "S" will appear on the display at the position where the stop code will be inserted.

4 Continue typing.

• Press the **CODE 1+P** keys for every location within the text that requires a stop code.

5 

When you have completed entering the text, press the **MENU** key again to store the stop codes and close your text.



3

To Print a Text with Stop Codes

When you print a text with stop codes, the unit will stop at each position where the "S" was entered. At that point, you may manually enter the variable information.

If your typing mode selection is set to "NORM", the variable will print as you enter it. If your typing mode selection is set to "DISP" or "JUST", the variable will print after pressing the **PRINT** key or a return. Regardless of the mode the variable was typed in, the **PRINT** key must be pressed after each stop code to resume printing the document.

1 Recall your text.

2  → 

Press the **PRINT** key.

Press the **RETURN** key after setting the printing parameters to start printing the text.

The text will begin to print up to the point where the first stop code was set.

• In the "DISP" or "JUST" mode, the text being manually inserted will appear on the display.

3 Enter your variable which will be inserted in the first position by typing it.

4 

Press the **PRINT** key to resume printing.

Continue inserting your variables until you have completed the text.



3-5 ENHANCED TYPING FEATURES

A Bold Print

You can instruct the unit to “highlight” certain words or characters for emphasis by using the bold print function.

1  +  Press the **CODE 1+B** keys.
The display symbol “” appears on the display.

2 Type the characters.



3  +  Press the **CODE 1+B** keys again to cancel the command.
The display symbol “” appears on the display.

B Underlining



You can instruct the unit to “underline” certain words or characters for emphasis by using the underlining function.

Continuous Underlining

3

1  +  Press the **CODE 1+U** keys.
The display symbol “” appears on the display.



2 Type your information. All characters and spaces will be underlined.

3  +  Press the **CODE 1+U** keys again to cancel the command.
The display symbol “” appears on the display.

Word by Word Underlining

1  +  Press the **CODE 1+W** keys.
The display symbol “” appears on the status line.



2 Type your information. Only characters will be underlined.
• Spaces will not be underlined.

3  +  Press the **CODE 1+W** keys again to cancel the command.
The display symbol “” appears on the display.

C Decimal Tabulation



You may use the **CODE 1+TAB** keys in place of the **TAB** key when typing statistical formats. The unit will automatically align decimal points at the preset tab stops and eliminate the need to space to the correct starting position in a column.

This function also can be used when typing formats which include characters.

- 1  +  Press the **CODE 1+TAB** keys.
The cursor will move to the first tab position and the display symbol "**D**" appears on the display.

- 2 Enter the numbers and decimal point.

```
NORM 10 1 I *New File*
L.....2.....T.....4.....T.....5.....T.....
          D 123.64 E
```

- 3  +  Press the **CODE 1+TAB** keys.
The decimal points of the first column will be positioned on the first tab stop and the cursor will move to the next tab position.

Repeat the above steps until you have completed all of your column entries.



•To cancel the decimal tabulation command, press the **CANCEL (⊗)** key.

D Centering

The unit has three ways to center information; between margins, between tab stops, over a specified point.



Between Margins

- 1  Press the **RETURN** key to position the cursor at the left margin.

- 2  +  Press the **CODE 1+C** keys to move the cursor to the center of the margins. The display symbol "**C**" appears on the display.



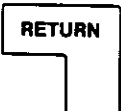

- 3 Enter the information to be centered.

```
NORM 10 1 I *New File*
L.....2.....T.....4.....T.....5.....T.....
          C Center E
```



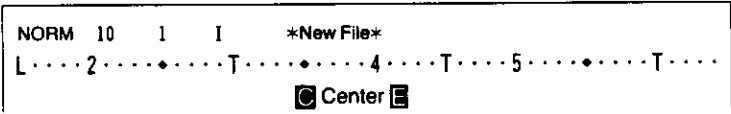

- 4  /  Press the **RETURN** or **TAB** key.
The information entered will be centered between the margins* and the centering command will be cancelled.

*When the indent function is in operation, centering is performed between the indented position and the right margin.

Between Tab Stops



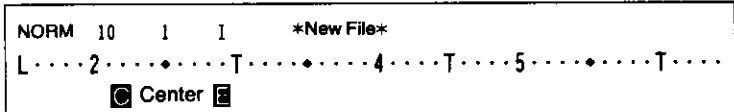

- 1  Press the **TAB** key to position the cursor at the left side tab position of the column you want to center in.
- 2  +  Press the **CODE 1+C** keys to move the cursor to the center of the tab stops.
- 3 Enter the information to be centered.

- 4  /  Press the **RETURN** or **TAB** key. The information entered will be centered between the tab stops and the centering command will be cancelled.

3 Over a Specified Point

- 1  Press the **SPACE BAR** to move the cursor to the desired position.
- 2  +  Press the **CODE 1+C** keys. Enter the information to be centered.

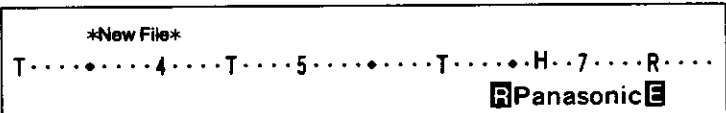
- 3  /  Press the **RETURN** or **TAB** key. The information entered will be centered and the centering command will be cancelled.

E Right Margin Flush

This command instructs the unit to print the information with the last character of each line aligned at the right margin. You can use this function to conveniently type dates or addresses.

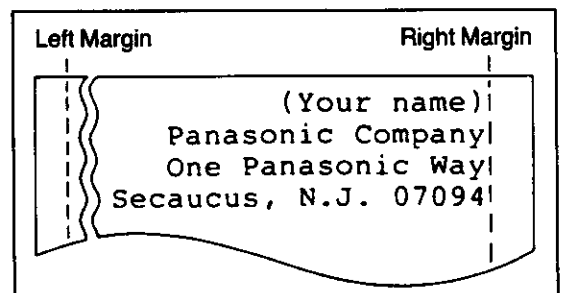

- 1  +  Press the **CODE 1+R** keys to move the cursor to the right margin. The display symbol "" appears on the display.
- 2 Enter the information.

- 3  Press the **RETURN** key. The characters will be entered with the last character right margin flush. The command will then be cancelled.



F Paragraph Indent

This command provides you with the ability to set a temporary left margin and eliminates the need to position the cursor to an indented location on every line.

1  /  Press the **TAB** key or the **SPACE BAR** to move the cursor to the desired indented position.

2  +  Press the **CODE 1+I** keys.
This sets the indented (temporary left margin) position.
The display symbol "⌘" appears on the display and the ruler line indicates the indent position.

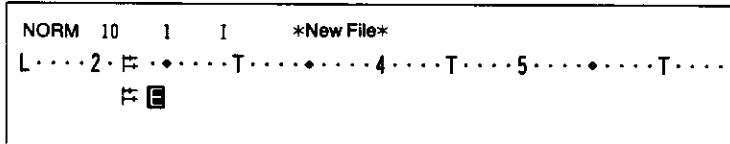

3 Type the characters.



Press the **RETURN** key to move the cursor to the indented position on the next line.

4 Continue typing.

5  + 

Press the **CODE 1+I** keys again to cancel the command.
The symbol "⌘" will appear on the display and disappear from the ruler line.
The cursor will move to the original left margin when the **RETURN** key is pressed.

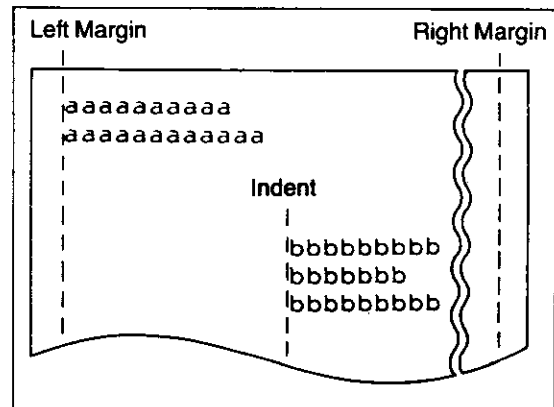

G Permanent Hyphen



If you press the **CODE 1+HYPHEN (-)** keys within the "Hot Zone", in the Word Processor Mode, the unit will continue printing without generating an automatic return. This coded hyphen is called a "Permanent Hyphen". It is indicated by the symbol "-" on the display and will be printed at the same point every time you print this text.

When you reach the end of a line, you may need to hyphenate a word to stay within your margin settings. In this case, press the "-" key and enter the next character. The hyphen will be printed and the cursor will automatically return to the left margin of the next line. This hyphen which is used temporarily in the "Hot Zone", is called a "Temporary Hyphen". It is indicated by the symbol "=" on the display. If you change the margin setting, the hyphen will not be printed unless it falls within the "Hot Zone".

H Permanent Space

3

Since your unit allows you to enter with automatic returns or with a justified margin, there may be times you do not want to separate characters or words. The unit allows you to set a "Permanent Space" between characters and will not separate them when printing with variable line lengths.

1 Type the first word.

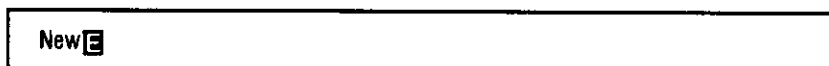

2  +  Press the **CODE 1+SPACE BAR**.



3 Type the second word.

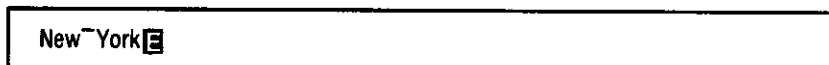



When the characters are entered, the unit will recognize the two words as one and will not separate them.

I Caps Lock

To set the unit for typing capital letters, lower case numbers, punctuation marks and symbols:

Press the **CODE 1+LOCK** keys.

In this mode, the **SHIFT** key will call for opposite characters to be entered.

1  +  Press the **CODE 1+LOCK** keys. The caps lock mode is activated and the display message "CP.LOCK" appears on the status line.

2 Type the text.

3  +  Press the **CODE 1+LOCK** keys again to cancel the command.

J Micro Spacing



Pressing the **CODE 1+J** keys moves the carriage by $\frac{1}{60}$ inch. You may use this function to “squeeze” characters together. The symbol “...” will appear on the display.

K Half Space



Pressing the **CODE 1+H** keys reduces the normal carriage spacing by one half. The symbol “- -” will appear on the display.

L Embedding the Display Symbols

While working with the display, symbols appear for the various commands you have instructed the unit to perform. As a result, your text will shift one character to the right for each display symbol. Many times it is difficult to visualize how your text will look with these symbols on the display.

To embed or “hide” these symbols:



Press the **CODE 1+E** keys.

Your text will appear without the symbols and you will be able to see your text as it will print.

To show the display symbols:

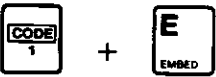

Press the **CODE 1+E** keys again.

M Typing Impression Control

This controls the impact of the printed characters. Select one of the three typing impression levels that is most suited for your needs.



Press the **CODE 1+8** keys to change the typing impression level. The following line appears at the bottom of the display.

Impression : Light Medium Heavy

You can select one of three typing impression levels: “Light”, “Medium” or “Heavy”. Select the desired impression level by using the **ARROW** keys and press the **RETURN** key.

- “Light” is softer than “Heavy”.
- At first, try “Light” and if you feel the impression level is too soft, try “Medium” or “Heavy”.
- Each time the **POWER** switch is turned on, the impression level is reset to “Light”.

You can also change the typing impression level in the printing parameters.

4-1 USING THE MICRO-FLOPPY DISK

In order to store the information in your Text/Address List/Auto Column Plus/User's Dictionary memory onto a disk, you must first prepare the disk to be used in the unit. This is done through a procedure called "formatting".

A Formatting the Disk

Formatting prepares the disk for the type of machine you are using. Each disk must be formatted before it can be used. If there are files on the disk, they will be automatically erased when the disk is formatted.

After inserting the disk into the disk drive (refer to p.16 "Inserting the Micro-Floppy Disk"):

1  Press the **MENU** key.

2 **ARROW** keys (↑↓←→) Select "Utility and Tutorial" by using the **ARROW** keys or entering "9".

or 

3  Press the **RETURN** key.

Utility and Tutorial

- | | |
|--------------------------|-------------------------------------|
| 1. Delete File from Disk | 5. Show Directory |
| 2. Rename File | 6. Load User's Dictionary from Disk |
| 3. Copy Disk | 7. Store User's Dictionary to Disk |
| 4. Format Disk | 8. Tutorial |

Select function then press RETURN. Press MENU to return to Main Menu.

4 **ARROW** keys (↑↓←→) Select "Format Disk" by using the **ARROW** keys or entering "4".

or 

5  Press the **RETURN** key.

Format Disk

Formatting a disk prepares it for use on this system.
This action will delete all files from the disk.
Continue?

Yes-RETURN / No-

6  Press the **RETURN** key to start formatting.

Press the **CANCEL** () key if you do not wish to format the disk.

NOTE:

It is not necessary to format the Tutorial Disk. It is already formatted and ready for use. Do not attempt to use the Tutorial Disk in any other machine.

B Storing a Text to the Disk

The unit allows you to store the entire contents of the text memory at one time. Because the disk can hold 353 KB, the entire memory contents may be stored to the same disk several times. Your text will remain in the text memory after it is stored to disk, but will be cleared if the **POWER** switch is turned **Off**.

To save text created in the Word Processor Mode to disk, perform the following steps.

- 1  Press the **MENU** key.

Main Menu	
1. Typewriter Mode	5. Store Text File to Disk
2. Create Text	6. Mail Merge
3. Edit Text	7. Address List
4. Load Text File from Disk	8. Auto Column Plus
	9. Utility and Tutorial

Select function then press RETURN.

- 2 **ARROW** keys (↑↓←→) Select "Store Text File to Disk" by using the **ARROW** keys or entering "5".

or 

- 3  Press the **RETURN** key.
The display will show "Reading disk.", and then the file name list will appear.

Store Text File to Disk	Space Available = 353 (KB)
No files on the disk!	
File Name =	

- 4 Enter a file name. ●A maximum of 10 characters can be used to name the file.

- 5  Press the **RETURN** key.

Storing file.

When the text has been stored on the disk, the display will return to the Main Menu.

●Press the **MENU** key to cancel the disk drive operation.

Remember, the text you have stored on your disk is still in the text memory. If you want to delete it, follow the procedures outlined in the "To Clear a Text from Memory" section of this manual (P. 52).

IMPORTANT: If you store a text from the text memory to the disk and the same name is already stored on the disk, the display will show:

Same file name already exists on the disk. Do you want to replace the existing file with the new file in memory? File Name =
Yes-RETURN / No- <input checked="" type="checkbox"/>

4

C Loading a Text File from the Disk to Memory

When you have stored information from the text memory onto a disk, you may clear your memory and continue with additional projects. The disk drive gives you the ability to take a text stored on disk, and LOAD it back into text memory whenever you need it.

- 1  Press the **MENU** key.

```
Main Menu
  1. Typewriter Mode          5. Store Text File to Disk
  2. Create Text              6. Mail Merge
  3. Edit Text                7. Address List
  4. Load Text File from Disk 8. Auto Column Plus
                               9. Utility and Tutorial

Select function then press RETURN.
```

- 2 **ARROW** keys (↑↓←→) Select "Load Text File from Disk" by using the **ARROW** keys or entering "4".

or 

- 3  Press the **RETURN** key.
The display will show "Reading disk.", and then the file name list will appear in alphabetical order.

```
Load Text File from Disk          Space Available = 330 (KB)
AAA          10 (KB)
BBB          13

Type file name or use ARROW keys then press RETURN. Press MENU to exit.
File Name =      NEXT PAGE/CODE 1+NEXT PAGE-Next/Previous screen
```

The first display is capable of showing a maximum of 16 file names.

- If a disk contains more than 16 file names, press the **NEXT PAGE** or **CODE 1+NEXT PAGE** key(s) to show the next or previous display.

- 4 **ARROW** keys (↑↓←→) Select the name of the file to be loaded by using the **ARROW** keys or entering the file name.
or
Enter the file name.

```
File Name =
```

- 5  Press the **RETURN** key.

```
Loading file.
```

When loading is completed, your display will show the first page of the text.

- Press the **MENU** key to cancel loading the file.

IMPORTANT: If you already have a text in the text memory, the display will show:

```
Text file already exists in memory.
This action will delete the existing file.
Continue?

Yes-RETURN / No-
```

D Renaming a File

1  Press the **MENU** key.

2 **ARROW** keys (↑↓←→) Select "Utility and Tutorial".

or 

3  Press the **RETURN** key.

Utility and Tutorial	
1. Delete File from Disk	5. Show Directory
2. Rename File	6. Load User's Dictionary from Disk
3. Copy Disk	7. Store User's Dictionary to Disk
4. Format Disk	8. Tutorial

Select function then press RETURN. Press MENU to return to Main Menu.

4 **ARROW** keys (↑↓←→) Select "Rename File " by using the **ARROW** keys or entering "2".

or 

5  Press the **RETURN** key.

Select File Type
1. Text File
2. Address List File
3. Auto Column File
4. User's Dictionary File

Select file type then press RETURN. Press MENU to exit.

6 **ARROW** keys (↑↓←→) Select "Text File" by using the **ARROW** keys or entering "1".

or 

7  Press the **RETURN** key.
The display will show the file name list.

8 **ARROW** keys (↑↓←→) Select the name of the file to be renamed by using the **ARROW** keys or entering the name.
or
Enter the file name.

File Name =

9  Press the **RETURN** key.

New Name =

10 Enter the new name.

11 

Press the **RETURN** key.

Renaming file.

After renaming, the display will return to the Utility Menu.

• If the new name you entered is already being used, the display will show:

Same file name already exists.

Retype the new name.

Similarly, you can rename an address list file, an auto column file or a user's dictionary file with this method.

• **When renaming an address list file:**

Select "Address List File" at step 6.

• **When renaming an auto column file:**

Select "Auto Column File" at step 6.

• **When renaming a User's Dictionary file:**

Select "User's Dictionary File" at step 6.

Your file is now renamed. In the future, the new name should be used because the original is no longer on the disk.

4

E Showing the File Names on the Disk

You may request the unit to list all the names of the files you have stored on a disk.

1 

Press the **MENU** key.

2 **ARROW** keys (↑↓←→)

Select "Utility and Tutorial".

or 

3 

Press the **RETURN** key.

Utility and Tutorial

1. Delete File from Disk	5. Show Directory
2. Rename File	6. Load User's Dictionary from Disk
3. Copy Disk	7. Store User's Dictionary to Disk
4. Format Disk	8. Tutorial

Select function then press RETURN. Press MENU to return to Main Menu.

4 **ARROW** keys (↑↓←→)

Select "Show Directory" by using the **ARROW** keys or entering "5".

or 

5 

Press the **RETURN** key.

After reading the disk, the display will show each file name and size, and the amount of available space on the disk.

Printing a List of the File Names

- 1 Perform the steps 1–5 on p.64.



Press the **PRINT** key.

The name and size of the files and the amount of available space on the disk will be printed.

- List printing will stop after printing 50 lines, and then the display will show "Page End!".

To continue printing, press the **RETURN** key.

To cancel list printing, press the **CANCEL (⊗)** key.

- If you want to stop printing the list, press the **PRINT** key.

F Appending a Text

The unit allows you to insert an existing text into another text.

- 1 Recall the text you want to add another text to.
- 2 Position the cursor at the location where you want to insert second document.



Press the **CODE 1+T** keys.

The display will show the file name list.

- 4 **ARROW** keys (↑↓←→)
or
Enter the file name.

Select the name of the file to be inserted/appended by using the **ARROW** keys or entering the name.

5 



Press the **RETURN** key.



After inserting/appending, the display will show the last position of the inserted/appended text.

- The entire original text and the entire inserted/appended text will now be in the text memory.

G Copying an Entire Disk

1  Press the **MENU** key.

2 **ARROW** keys (↑↓←→) Select "Utility and Tutorial".
or 

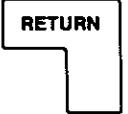
3  Press the **RETURN** key.

Utility and Tutorial

1. Delete File from Disk	5. Show Directory
2. Rename File	6. Load User's Dictionary from Disk
3. Copy Disk	7. Store User's Dictionary to Disk
4. Format Disk	8. Tutorial

Select function then press RETURN. Press MENU to return to Main Menu.

4 **ARROW** keys (↑↓←→) Select "Copy Disk" by using the **ARROW** keys or entering "3".
or 

5  Press the **RETURN** key.

Copy Disk

This action will delete all files from the Destination Disk.
This action will delete the file from memory.
Continue?

Yes-RETURN / No-

6  Press the **RETURN** key.

7 Insert the source disk into the disk drive. •The **source disk** is the disk you want to copy from.

8 Press any key. The machine begins reading information from the source disk.

Reading source disk.

9 Eject the source disk and insert the destination disk into the disk drive when prompted. •The **destination disk** is the disk you want to copy to.

10 Press any key. The machine begins writing information to the destination disk.

Writing destination disk.

11 Repeat steps 7-10 as prompted. The entire contents of the destination disk is deleted and replaced with the contents of the source disk.

When the entire contents of the source disk drive have been copied to the destination disk, the display will return to the Utility Menu.

IMPORTANT: If you already have a text in the text memory, the display will prompt:

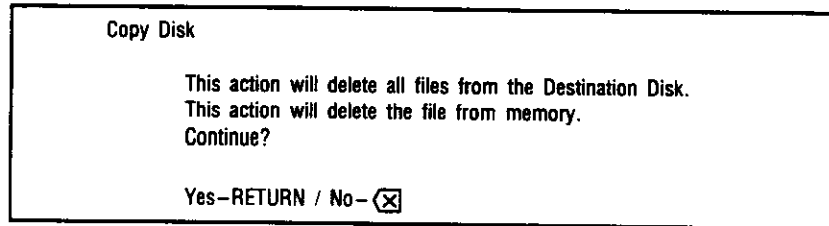

- Press the **RETURN** key to continue.
- Press the **CANCEL** ([X]) key to escape.

H Deleting a File from the Disk

When you no longer need a particular file, or need the space to store a new file, you can delete an old file from the disk as follows:

1  Press the **MENU** key.

2 **ARROW** keys (↑↓←→) Select "Utility and Tutorial".

or 

3  Press the **RETURN** key.

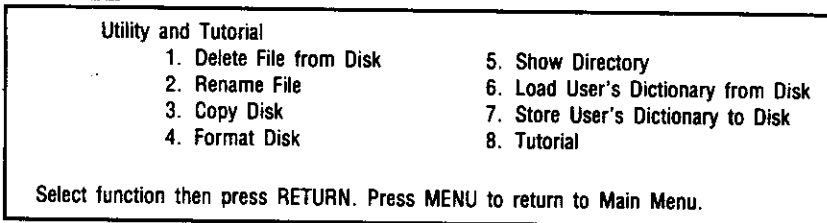

4 **ARROW** keys (↑↓←→) Select "Delete File from Disk" by using the **ARROW** keys or entering "1".

or 

5  Press the **RETURN** key.

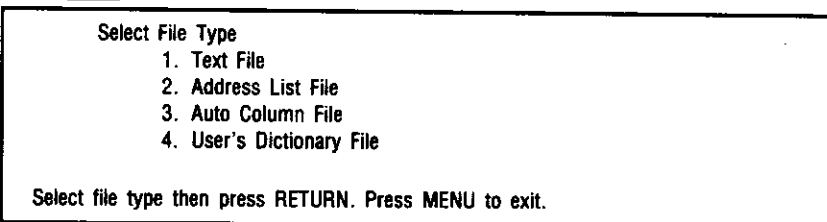

6 **ARROW** keys (↑↓) or Select "Text File".





Press the **RETURN** key.
The display will show the file name list.

8 ARROW keys (↑↓←→)
or
Enter the file name.

Select the name of the file to be deleted by using the **ARROW** keys or entering the name.

File Name =



Press the **RETURN** key.

Delete File from Disk

Do you want to delete this file from the disk?
Yes-RETURN / No-

Delete File Name =

4



Press the **RETURN** key.

Deleting file.

The display will return to the file type list after the file has been deleted.



Press the **MENU** key to return to the Utility Menu.

Similarly, you can delete an address list file, an auto column file or a user's dictionary file with this method.

- **When deleting an address list file:**
Select "Address List File" at step 6.
- **When deleting an auto column file:**
Select "Auto Column File" at step 6.
- **When deleting a user's dictionary file:**
Select "User's Dictionary File" at step 6.

5-1 MAIL MERGE

Mail merge allows you to merge a form letter requiring variable information with a mail list. This application enables you to create personalized letters for each person on your mail list with the respective variable information inserted automatically.

The unit also allows you to selectively print from your mail list. This is done by entering a qualifying line (maximum of 30 characters) before each address block. This qualifying line allows you to instruct the unit to selectively merge names and addresses that fall within a specific category.

Mail merge can also be instructed to print only the address from the mail list enabling you to address an envelope or label without retyping.

A Creating a Form Letter

A form letter containing the constant information is entered into the text memory as normal text. **Reference codes** (\bar{V}) are inserted into the letter where the variable information in the mail list is to be inserted. Regardless of the number of lines of variable information (i.e., an address), only one reference code is required. When you enter a reference code in the body of the letter, be sure to enter a space before and after the reference code so that the variable information does not run into the other text.

Creating a Reference Code



Press the **CODE 1+V** keys.

Your display will show a (\bar{V}) with an overscore. This tells the system to refer to the mail list for the variable information.

Mail merge inserts the variable information into the form letter in the order it appears in the mail list. Therefore, always use the first reference code for the name and address so that the mail list can be used to print envelopes and labels.

Below is an example of a form letter. Please complete all the exercises in this section so that you become comfortable with the mail merge application.

5

Enter the Word Processor Mode.

Set your original left margin at 10.

Set your original right margin at 70.

Set your page length to 60.

Set your typing mode to "JUST".

Enter the following form letter into the text memory and store it to disk naming it "OVERDUE". Be sure to use the CODE 1+V keys for each reference point shown in the following example:

```
(Today's Date)↵
↵
↵
↵
Dear  $\bar{V}$ :↵
↵
A copy of Invoice No.  $\bar{V}$  was sent to your office on  $\bar{V}$ . This
invoice was issued for the shipment of  $\bar{V}$ , which was ordered
from us.↵
↵
Your balance is now  $\bar{V}$  days past due and we would appreciate
your payment within the next 15 days. If your check of  $\bar{V}$ 
has been sent, please accept our thanks and disregard this
notice.↵
↵
Sincerely,↵
↵
↵
↵
Lee Hayes↵
Hayes Office Equipment↵
↵
LH/m↵
```

B Creating a Mail List

The mail list is created in the text memory and stored to a disk under a separate file name, and it contains all variable information necessary to merge into the form letter. Each variable to be merged into the form letter is enclosed in parentheses ().

Manual returns entered within the parentheses are inserted into the form letter and will cause a return at that point. Manual returns entered outside the parentheses do not affect the print out of the form letter. They simply separate each variable and make it easier to read the mail list if printed out. An example of a mail list with and without returns after each variable is shown below.

Each group of variable information (i.e., name and address, account number, etc.) is called a **record**. Each record is separated by the **CODE 1+SLASH (/)** keys in the mail list.

1 Enter the Word Processor Mode.

2  +  Press the **CODE 1+SLASH (/)** keys.

3  Press the **RETURN** key.

4  +  Type an opening Parenthesis "(".

5 Type the variable information.

6  +  Type a closing Parenthesis ")".

7 Repeat steps 4~6. Continue entering each variable for the letter with parenthesis.

8 Repeat for each record or group of variables.

Below is an example of the same mail list entered with returns after each variable (unpacked) and without returns after each variable (packed).

Open a new text and enter the following mail list into the memory in the style you prefer. Store the text to the disk naming it "LATE ACCTS".

UNPACKED

```

7↵
(Mrs. Monica Simpson↵
289 Hicks Street↵
New York, NY 10004)↵
(Mrs. Simpson)↵
(B1343)↵
(12/12/86)↵
(5½ inch disks)↵
(60)↵
($325.80)↵
7↵
(Mrs. Alicia Prichett↵
131 Ascan Avenue↵
Summit, NJ 07901)↵
(Mrs. Prichett)↵
(B0984)↵
(1/12/86)↵
(marking pens)↵
(30)↵
($197.65)↵
7↵
(Mr. Paul Smith↵
1985 Harrison Road↵
Ridgefield Park, NJ 07660)↵
(Mr. Smith)↵
(B2589)↵
(12/22/86)↵
(magnetic tapes)↵
(60)↵
($321.25)↵

```

PACKED

```

7↵
(Mrs. Monica Simpson↵
289 Hicks Street↵
New York, NY 10004)↵
(Mrs. Simpson)(B1343)(12/12/86)(5½ inch disks)(60)($325.80)↵
7↵
(Mrs. Alicia Prichett↵
131 Ascan Avenue↵
Summit, NJ 07901)↵
(Mrs. Prichett)(B0984)(1/12/86)(marking pens)(30)($197.65)↵
7↵
(Mr. Paul Smith↵
1985 Harrison Road↵
Ridgefield Park, NJ 07660)↵
(Mr. Smith)(B2589)(12/22/86)(magnetic tapes)(60)($321.25)↵

```

C Merging a Form Letter and Mail List

Each letter will print with the margins and tab set when the form letter was stored.

- 1  Press the **MENU** key.

```
Main Menu
  1. Typewriter Mode          5. Store Text File to Disk
  2. Create Text              6. Mail Merge
  3. Edit Text                7. Address List
  4. Load Text File from Disk 8. Auto Column Plus
                               9. Utility and Tutorial

Select function then press RETURN.
```

- 2 **ARROW** keys (↑↓←→) Select "Mail Merge" by using the **ARROW** keys or entering "6".

or 

- 3  Press the **RETURN** key.
The display will show the file name list.

```
Mail Merge                               Space Available = 328 (KB)
AAA                                     10
BBB                                     13
LATE ACCTS                             1
OVERDUE                                 1
```

- 4 **ARROW** keys (↑↓←→) Select the file name of the form letter by using the **ARROW** keys or entering the name.
Enter the file name.

```
Form Letter = OVERDUE
```

- 5  Press the **RETURN** key.

- 6 **ARROW** keys (↑↓←→) Select the file name of the mail list by using the **ARROW** keys or entering the name.
Enter the file name.

```
Mail List = LATE ACCTS
```

5



Press the **RETURN** key.
The display will show the Mail Merge parameters.

Mail Merge		Left Margin = 10
Qualifier : █	(Select records from a Mail List)	Right Margin = 70
Page Numbering : N	(1,2...:start number)	Page Length = 60
	(N:no numbering)	
Print Impression : 1	(1-Light/2-Medium/3-Heavy)	
Set parameters then press RETURN. Press MENU to exit.		

To change a parameter, select it by using the **ARROW** keys and enter the desired value.

- The qualifier is used to selectively print records from your mail list. This operation will be covered in the next section.

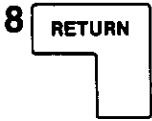

Press the **RETURN** key.

Mail merge will start and the form letter will be displayed containing the information from the first record.

- If you want to display the form letter merged with the information from the next record, press the **CANCEL** () key.

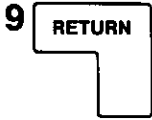

Press the **RETURN** key to start printing.

After printing, the display will show the form letter merged with the information from the next record.

If you want to print it, press the **RETURN** key.

If you want to stop merging, press the **MENU** key.

When merging has been entirely completed, the display will return to the Main Menu.

- If a file already exists in the memory, the display will show:

Text file already exists in memory. This action will delete the existing file. Continue? Yes-RETURN / No- <input checked="" type="checkbox"/>
--

- If a record does not exist in the mail list, the display will show:

CODE 1+ / not found in the mail list.

Press any key to return to the file name list.

- When the form letter includes more reference codes than variables in the mail list, the display will show:

Reference code mismatch!

Then the unit will continue merging with replacing superfluous codes with one space.

D Creating a Qualified Mail List

If you do not have a qualifying line before each record of variables, you cannot qualify or selectively print from your mail list. The qualifying line can be a maximum of 30 characters and must appear as the first line of each record. You can use the 30 characters to create as many qualifying categories as you'd like (i.e., zip code, state, occupation, etc.). These qualifiers do not have to be associated with the variables in the mail list.

If you wanted to select individuals by zip code, you'd enter the zip code on the qualifying line. If you also wanted to select by state, that too would be entered on the qualifying line. The group of characters representing one category is called a **field**. The state and zip code would represent two fields. Each field must be separated by a space.

- Add a qualifying line to each record in the mail list "**LATE ACCTS**" by loading it from the disk, adding the qualifying information and storing it to disk again.

Use the caps lock feature when typing the qualifying line as shown below:



```
7NY 10004 $325 60␣  
(Mrs. Monica Simpson␣
```

```
7NJ 07901 $197␣  
(Mrs. Alicia Prichett␣
```

```
7NJ 07660 60␣  
(Mr. Paul Smith␣
```

E Selecting from a Qualified Mail List

5

- 1  Press the **MENU** key.
- 2 ARROW keys (↑↓↔) Select "Mail Merge".
or 
- 3  Press the **RETURN** key.
- 4 ARROW keys (↑↓↔) Select or enter the file name of the form letter.
or
Enter the file name.

```
Form Letter =
```

- 5  Press the **RETURN** key.
- 6 ARROW keys (↑↓↔) Select or enter the file name of the mail list.
or
Enter the file name.

```
Mail List =
```

7



Press the **RETURN** key.

• If you need to change the parameters, select and enter the desired value.

Mail Merge	
Qualifier : █	
(Select records from a Mail List)	
Page Numbering : N	(1,2...start number) (N:no numbering)
Print Impression : 1	(1-Light/2-Medium/3-Heavy)
Set parameters then press RETURN. Press MENU to exit.	

Left Margin	= 10
Right Margin	= 70
Page Length	= 60

8 Enter each qualifying field in the mail list.

Remember to separate each field with a space.

9



Press the **RETURN** key.

Mail merge will start and the form letter will be displayed containing the information from the qualified record.

10



Press the **RETURN** key to start printing.

• If a qualified record does not exist in the mail list, the display will show:

No qualified records!

Press any key to return to enter a new qualifier.

5

Wildcards

You can use wildcards to instruct the system to select any character in a field or ignore the remainder of the fields on the qualifying line.

EXAMPLE:

Qualifier : 07 \$197

All zip codes starting with 07

Press the **RETURN** key to by-pass each prompt.

To do the following exercise, press the **MENU** key and merge the form letter "OVERDUE" with the mail list "LATE ACCTS".

• Send a letter to all customers in "NJ" with a zip code beginning with "07".

The qualifying prompts should read:

Qualifier : NJ 07

or

Qualifier : 07 NJ

Two letters should print.

• Send a letter to all customers living in "NY".

The qualifying prompts should read:

Qualifier : NY

One letter should print.

F Printing Envelopes and Labels

As we learned earlier, Mail Merge requires two components, a form letter and a mail list. When printing envelopes or labels, a **dummy text** containing only **CODE 1+V** and **RETURN** is needed to print only the first variable. Therefore, always enter the name and address as the first variable in the mail list. You may need more than one dummy text (different names) since envelopes and labels require different formats for printing.

Creating a Dummy Text

1 Enter the Word Processor Mode.

2 Set margins for the envelope or label.

3  + 

Press the **CODE 1+V** keys to enter the reference code.
This instructs the system to pull the first variable from the mail list.

4 

Press the **MENU** key to store the text to the disk.

5 ARROW keys (↑↓←→)

Select "Store Text File to Disk" and press the **RETURN** key.

or 

→ 

6 Enter a document name.

7 

Press the **RETURN** key.

Remember, when merged, the mail list will print within the format of the form letter.

Printing Envelopes and Labels

1 Insert an envelope or label.

2  Press the **MENU** key.

3 ARROW keys (↑↓←→) Select "Mail Merge" and press the **RETURN** key.

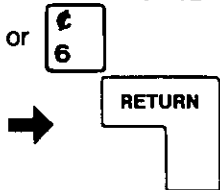

4 ARROW keys (↑↓←→) Select or enter the form letter name of the "dummy text" and press the **RETURN** key.

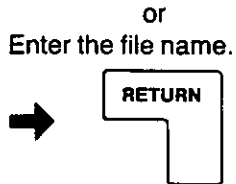

5

5 ARROW keys (↑↓←→) Select or enter the mail list name and press the **RETURN** key.
or
Enter the file name.
•If you need to change the parameters, select and enter the desired value.



6 Enter a qualifier if desired.

7  Press the **RETURN** key.
The address from the first record will be displayed.

8  Press the **RETURN** key to start printing.
•If you want to display the next address, press the **CANCEL** (⊗) key.

9 Insert another envelope or label.

10 Repeat step 8.

● If a file already exists in the memory, the display will show:

Text file already exists in memory.
This action will delete the existing file.
Continue?

Yes-RETURN / No-

To delete the existing file and enter the Address List Menu, press the **RETURN** key.
To retain the existing file, press the **CANCEL** () key and the Main Menu will appear.

A To Create Records and Store to the Disk

1 ARROW keys (↑ ↓ ← →) Select "Create Record" by using the **ARROW** keys or entering "1" in the Address List Menu.

or 1

2 RETURN Press the **RETURN** key.
The current record number will appear at the bottom of the display.

3 Type the information to be stored to each term. Do not exceed;

Name	80 characters
Address	150 characters
Phone No.	30 characters
Memo	30 characters

For example, enter the following record.

Name: Mrs. Monica Simpson

Address: 29 Hicks Street

New York, NY 10004

Phone No.: 123-456-7890

Memo: Doctor (surgeon) Record No.:1

ARROW keys (↑ ↓)

You must use the **DOWN/UP ARROW** keys to move the next/previous term.

● If you want to sort the records according to each last name, press the **CODE 1+Q** keys between the first name and the last name of each "Name" term. The display will show a rectangular () symbol. This operation will be covered in "To Sort Records in Alphabetical Order" on p. 82.

● If you attempt to enter more than the above number of characters in "Name", "Address", "Phone No." or "Memo" terms, the display will show:

Term too long!

NOTE:

All information stored in the memory is cleared when the **POWER** switch is turned **Off**. For permanent storage, address lists created in the Address List Memory must be stored on the micro-floppy disk.

4 

If you want to store more records, press the **NEXT PAGE** key to move to the next record and repeat the above step 3.
 ● You can store a maximum of 999 records. If you attempt to enter more than 999 records, the display will show:

Too many records!

5 

Press the **MENU** key to close the record.
 The display will show the record table.

New File		
No.	NAME	ADDRESS
1	Mrs. Monica Simpson	29 Hicks Street ↵
2	(NEW RECORD)	

The entered records will be listed with "Name" and "Address" terms in input order.

6 

Press the **MENU** key to return to the Address List Menu.

Address List

1. Create Record	5. Sort in Alphabetical Order
2. Edit Record	6. Delete All Records from Memory
3. Load File from Disk	
4. Store File to Disk	

Select function then press RETURN. Press MENU to return to Main Menu.

6

7 **ARROW** keys (↑ ↓ ← →) or 

Select "Store File to Disk" by using the **ARROW** keys or entering "4".

8 

Press the **RETURN** key.

	Store Address List File to Disk	Space Available = (KB)
Name	Size (KB)	
File Name =	█	

9 Enter a name of the address list file.

Do not exceed ten (10) characters.



Press the **RETURN** key.

Storing file.

When storing is completed, the display will return to the Address List Menu.



Press the **MENU** key to return to the Main Menu.

- If you store an address list from the memory to the disk and the same name is already stored on the disk at step 9, the display will show:

Same file name already exists on the disk.
 Do you want to replace the existing file
 with the new file in memory?
 File Name =
 Yes-RETURN / No-

- If you want to rename the address list file, refer to "Renaming a File" on p.63.

To practice the exercises in this manual, please enter the following names with **CODE 1+Q** keys and addresses, etc. and store the records onto the disk naming it "**ADDR LIST1**".

CODE 1+Q

Name: Mrs. Monica Simpson
 Address: 29 Hicks Street
 New York, NY 10004
 Phone No.: 123-456-7890
 Memo: Doctor (surgeon)

CODE 1+Q

Name: Mr. Paul Smith
 Address: 1985 Harrison Road
 Ridgefield Park, NJ 07660
 Phone No.: 483-591-6720
 Memo: Lawyer

CODE 1+Q

Name: Mrs. Alicia Pritchett
 Address: 131 Ascan Avenue
 Summit, NJ 07091
 Phone No.: 852-963-7410
 Memo: French Teacher

CODE 1+Q

Name: Mr. David Keith
 Address: 234 Ocean Blvd.
 East Harwich, MA 02645
 Phone No.: 158-942-6370
 Memo: Doctor (physician)

(↵): Press the **RETURN** key.)

B To Load an Address List File from the Disk

When you have stored an address list file from the memory onto a disk, you may clear your memory and continue with additional projects. The disk drive gives you the ability to take an address list file stored on disk, and load it back into memory whenever you need it.

- 1** ARROW keys (↑↓←→) Select "Load File from Disk" by using the **ARROW** keys or entering "3" in the Address List Menu.

or

```

Address List
1. Create Record           5. Sort in Alphabetical Order
2. Edit Record            6. Delete All Records from Memory
3. Load File from Disk
4. Store File to Disk

Select function then press RETURN. Press MENU to return to Main Menu.
    
```

- 2** Press the **RETURN** key. The display will show "Reading disk." and then the address list file will appear in alphabetical order.

```

Load Address List File from Disk      Space Available = 350 (KB)
ADDR LIST1      1
BBB             1
CCC             1

File Name = █
    
```

The first display is capable of showing a maximum of 16 file names. If a disk contains more than 16 file names, press the **NEXT PAGE** or **CODE 1+ NEXT PAGE** key(s) to show the next or previous display.

6

- 3** ARROW keys (↑↓←→) or Enter the file name. Select the name of the address list file to be loaded by using the **ARROW** keys or entering the name.

- 4** Press the **RETURN** key.

```

Loading file.
    
```

When loading is completed, the display will show the record table. You will also see the file name on the top of the display.

- If you already have an address list existing in memory, the display will show:

```



Address List file already exists in memory.
This action will delete the existing file.
Continue?

Yes--RETURN / No- 
    
```

Press the **RETURN** key to load the address list file. Press the **CANCEL** () key to cancel this operation and return to the Address List Menu.

C To Add to an Existing Address List

If you are interrupted while entering a record, simply end the information and continue it later.

- 1 **ARROW** keys (↑↓←→) Select "Create Record" in the Address List Menu after creating records or loading the address list file to store the additional information.
or 
- 2  Press the **RETURN** key.
- 3 Make new records and store the additional information to the disk. (Refer to the steps 3-10 of "To Create Records and Store to the Disk" on p. 78.)

D To Sort Records in Alphabetical Order

This feature will allow you to sort the records according to each last name using the **CODE 1+Q** keys between the first name and last name of each "Name" term.

When you enter a "Name" term using the **CODE 1+Q** keys each record will be sorted according to the first character after the sort rectangle (□). This means that spaces and numeric characters will appear prior to alphabet characters.

- 1 **ARROW** keys (↑↓←→) Select "Sort in Alphabetical Order" by using the **ARROW** keys or entering "5" in the Address List Menu after creating the records or loading the address list file to be sorted.
or 

6

Address List	
1. Create Record	5. Sort in Alphabetical Order
2. Edit Record	6. Delete All Records from Memory
3. Load File from Disk	
4. Store File to Disk	

Select function then press RETURN. Press MENU to return to Main Menu.

- 2  Press the **RETURN** key.

Sort in Alphabetical Order	
Sort records in alphabetical order according to the characters behind the Sort Rectangle (□) in the Name Term.	
Can not return to the previous order.	
Continue?	
Yes-RETURN / No- 	

- 3  Press the **RETURN** key for Yes or **CANCEL** () key for No.

To begin this exercise, please recall the file name "ADDR LIST1" from the disk and sort the records. After sorting, the display will show the record table as follows:

ADDR LIST 1		
No.	NAME	ADDRESS
1	Mr. David □ Keith	234 Ocean Blvd. ↵
2	Mrs. Alicia □ Pritchett	131 Ascan Avenue ↵
3	Mrs. Monica □ Simpson	29 Hicks Street ↵
4	Mr. Paul □ Smith	1985 Harrison Road ↵

E To Modify a Record

If you want to modify a record, do the following:

- 1 Perform the steps 1-2 of "To Load an Address List File from the Disk" on p. 81.

- 2 Select the file name.



Select the file name to be modified and press the **RETURN** key. The display will show the record table.

- The first display is capable of showing a maximum of 4 records. If you have more than 4 records, press the **NEXT PAGE** or **CODE 1+NEXT PAGE** key(s) to show the next or previous display.

- 3 **ARROW** keys (↑↓←→)



Select the record as you wish and press the **RETURN** key.

- 4 Modify the record.

- 5 Store the modified record.

Perform the steps 5~8 of "To Create Records and Store to the Disk" on p. 78.

- If the part to be modified is located toward the end of the current term, press the **RELOC** key to position yourself at the end of it.
- If the part to be modified is located toward the beginning of the current term, press the **CODE 1+RELOC** keys to position yourself at the beginning.
- If the part to be modified is located in another term, use the **ARROW** keys to move to the other term.
- If the part to be modified is located in the next record, press the **NEXT PAGE** key to move to the next record.
- If the part to be modified is located in the previous record, press the **CODE 1+NEXT PAGE** keys to move to the previous record.
- After the top record in memory has been displayed and the following message will appear on the display.

Top of list!

F Record Search

You can search directly to the record to be modified or printed on the record table.

- 1 **ARROW** keys (↑↓←→) Select "Edit Record" in the Address List Menu.



Press the **RETURN** key. The display will show the record table.



Press the **CODE 1+S** keys.

- 4 Enter "Name", "Address", "Phone No." or "Memo" (a maximum of 30 characters) you are searching for.

[For example, Smith]

```

Search Record
Name : Smith █
Address :
Phone No. :
Memo :

Enter search strings then press RETURN. Press MENU to exit.
  
```

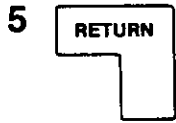

Press the **RETURN** key.

Your unit will start searching for the required records only by entered terms from the top of the table.

The display will show a table of the searched records.

- 6 Modify or print the record if necessary.

• If the record is not found in the list, the display will show:

```

Not found!
  
```

G To Copy a Record to Another Record

- 1 ARROW keys (↑↓←→)

Select "Create Record" in the Address List Menu after creating records or loading the address list file.



Press the **RETURN** key.

The display will show a new record.

6



Press the **CODE 1+3** keys.

```

Record No. = █
  
```

Enter the record number to be copied.

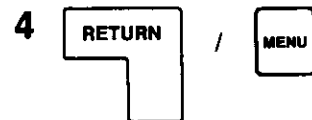

Press the **RETURN** key to copy the record to the new record.

If you do not want to copy it, press the **MENU** key.

• If the selected record is empty, the display will show:

```

Not found!
  
```

To practice the exercise, recall the file name "**ADDR LIST1**" and add the following record.

As you see, the following record is the same as record number 3 except for the "Name" and "Memo" terms. You can simply create the new record by copying record number 3 to it and changing the name and memo.

```

Name: Ms. Jill Simpson
Address: 29 Hicks Street █
        New York, NY 10004
Phone No.: 123-456-7890
Memo: Doctor (dentist)
  
```

H Printing from the Address List Memory

To Print the Address List

You have entered your records into memory or disk and now want to print them.

1 ARROW keys (↑↓←→) Select "Edit Record" in the Address List Menu.



2  Press the **RETURN** key.
The display will show the record table.

3  Press the **PRINT** key.

```

DISP 10 1 I Address List
From Record : 1          Print Address ? : Y (Y-Yes / N-No)
To Record : 4 (L:Last Record)  Phone No.? : N
Page Length : 60        Memo? : N
Print Impression : 1 (1-Light/2-Medium/3-Heavy)

Set parameters then press RETURN. Press MENU to exit.
    
```

Select the desired parameter by using the **ARROW** keys and change it, if necessary.

4  Press the **RETURN** key.
The unit will start printing your record.

Printing!

After printing, the display will show the record table.

•The unit will automatically print the records according to the following, independent of the current margin format.

PITCH	Name	SPACE	Address, Phone No. & Memo
10	26 chr.	4	36 chr.
12	31 chr.	4	43 chr.
15	38 chr.	6	53 chr.

•When the print reaches the end of the page, the display will show:

```

Page end!
Continue?

Yes-RETURN / No-(X)
    
```



Insert a new sheet of paper and press the **RETURN** key to continue or press the **CANCEL (X)** key to stop printing.

To Stop Printing in the Middle of the Record

- 1  Press the **PRINT** key during printing.





Continue printing?

Yes-RETURN / No-

- 2  /  If you want to exit the printing mode:
Press the **CANCEL** () key.
- If you want to continue printing the address list:
Press the **RETURN** key.

Your unit will resume printing from the point on the line where it stopped.

1 To Print a Record on an Envelope

- 1 **ARROW** keys () Select "Edit Record" in the Address List Menu and press the **RETURN** key.

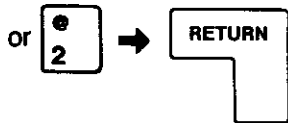

- 2 Select a record. Select the record you wish to print by using the **ARROW**, **CODE 1+S**, **NEXT PAGE**, or **CODE 1+NEXT PAGE** key(s).

- 3  Press the **RETURN** key.
The display will show the record.

- 4  Press the **PRINT** key.

DISP 10 1 I Address List

Print Phone No.? : N (Y-Yes / N-No)

Memo? : N

Print Impression : 1 (1-Light/2-Medium/3-Heavy)

Set parameters then press RETURN. Press MENU to exit.

Select the desired parameter by using the **ARROW** keys and change it, if necessary.

- 5  Insert an envelope and press the **RETURN** key.

Move carriage to desired printing position
with **SPACE BAR** or **BACKSPACE** key.

- Press the **SPACE BAR** or the **BACKSPACE** key to move the carriage to the desired position.
- Change the vertical position of the paper using the platen knob.

6  Press the **RETURN** key to start printing.

Printing!

7  After printing, press the **MENU** key.

8 Repeat the above steps 2-7.

To begin this exercise, recall the file name "**ADDR LIST1**" and print on an envelope as follows:

Mr. Paul Smith 1985 Harrison Road Ridgefield Park, NJ 07660	(Envelope)
Carriage position →	Mr. David Keith 234 Ocean Blvd. East Harwich, MA 02645

J To Delete a Record from Memory

When you no longer need a particular record, or need the space to enter a new record, you can delete an old record from memory as follows:

6

1 **ARROW** keys (↑↓←→) Select "Edit Record" in the Address List Menu.

or 



2  Press the **RETURN** key.

3 Select a record. Select the record to be deleted by using the **ARROW**, **CODE 1+S**, **NEXT PAGE**, or **CODE 1+NEXT PAGE** key(s).

4  Press the **RETURN** key.
The display will show the record.

5  +  Press the **CODE 1+CANCEL (⊗)** keys.

Delete this record? Yes-RETURN / No-⊗

6  /  Press the **RETURN** key for yes or **CANCEL (⊗)** key for no.
You can also delete a record on the record table by skipping the above step 4.

K To Delete All Records from Memory

When you no longer need all records in memory or need the space to enter new records, you can delete all records from memory as follows:

- If you want to delete an address list file from the disk, refer to "Deleting a File from the Disk" on p. 67.

1 ARROW keys (↑↓←→) Select "Delete All Records from Memory" by using the **ARROW** keys or entering "**6**" in the Address List Menu.

or 

Address List

1. Create Record	5. Sort in Alphabetical Order
2. Edit Record	6. Delete All Records from Memory
3. Load File from Disk	
4. Store File to Disk	

Select function then press RETURN. Press MENU to return to Main Menu.

2  Press the **RETURN** key.

Delete All Records from Memory

This action will delete all records from memory and create an Address List file.
Continue?

Yes-RETURN / No-

6

3  /  Press the **RETURN** key for yes or **CANCEL** () key for no.
After deleting all records, the display will show the Address List Menu.

- If a file already exists in the memory, the display will show:

Text file already exists in memory.
 This action will delete the existing file.
 Continue?

Yes-RETURN/ / No-

To delete the existing file and enter the Auto Column Plus Menu, press the **RETURN** key.

To retain the existing file, press the **CANCEL** () key and the Main Menu will appear.

A To Create an Auto Column File

- 1 **ARROW** keys ($\uparrow\downarrow\leftarrow\rightarrow$) Select "Create File" by using the **ARROW** keys or entering "1" in the Auto Column Plus Menu.

or

1

- 2 **RETURN** Press the **RETURN** key.
The display will show the auto column parameters.

Auto Column Plus

Number of Columns : (1-16)	Header Lines : (0-3)
Column Width : (5-13)	Data Lines : (1-30)
Print Pitch : 10 (10/12/15)	Footer Lines : (0-3)

Set parameters then press RETURN. Press MENU to exit.

- 3 **ARROW** keys ($\uparrow\downarrow\leftarrow\rightarrow$) Enter the required number of columns, column width, print pitch, header lines, data lines and footer lines by using the **ARROW** keys.
For example:

Number of Columns : 5 (A maximum of 16 columns can be set)
 Column Width : 13 (5 to 13 can be set)
 Print Pitch : 10 (10/12/15 can be set)
 Header Lines : 1 (A maximum of 3 lines can be set)
 Data Lines : 4 (A maximum of 30 lines can be set)
 Footer Lines : 1 (A maximum of 3 lines can be set)

- The figures of number of columns and column width must meet the following formulas.

(Number of Columns) × (Column Width + 1) + 3 ≤ 100 (10 pitch)

(Number of Columns) × (Column Width + 1) + 3 ≤ 120 (12 pitch)

(Number of Columns) × (Column Width + 1) + 3 ≤ 150 (15 pitch)



- If you enter the wrong data, the display will show:

Parameter error!

4 

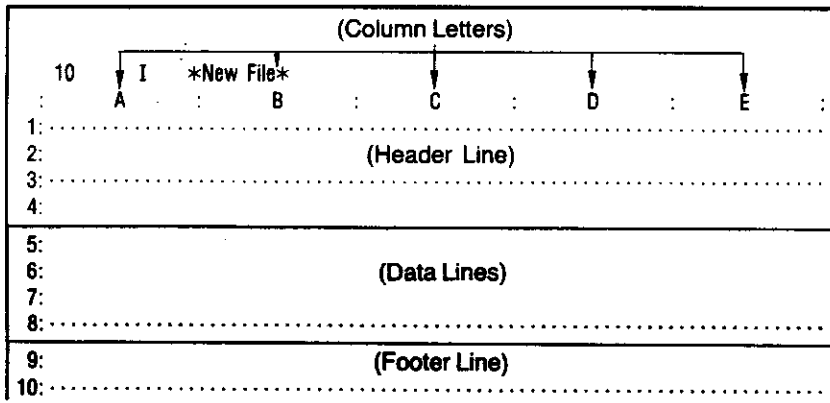
Press the **RETURN** key.
The display will show the column layout.



5  + 

Enter the data for each column.
You may use the **CODE 1+TAB** keys when entering the numbers into each column.

To practice the exercises in this manual, please enter the following data:

10	I	*New File*			
:	A	B	C	D	E
1:				
2:	<input type="checkbox"/> Age	<input type="checkbox"/> 1987	<input type="checkbox"/> 1988	<input type="checkbox"/> Total	<input type="checkbox"/> Increase N
3:				
4:	Twenties	<input type="checkbox"/> 1500	<input type="checkbox"/> 2000		
5:	Thirties	<input type="checkbox"/> 10000	<input type="checkbox"/> 15000		
6:	Forties	<input type="checkbox"/> 4500	<input type="checkbox"/> 7000		
7:	Fifties	<input type="checkbox"/> 2000	<input type="checkbox"/> 2300		
8:				
9:	<input type="checkbox"/> Total				
10:				

7

- The **RIGHT/LEFT ARROW** keys move the cursor to the next/previous column.
- You may use the **TAB** key in place of the **CODE 1+C** keys when centering the data.
- The maximum width of one column is equal to 15 characters.
- In each column, a maximum of 13 characters can be entered. The number of characters is 2 characters less than the column width. If this number of characters is exceeded, the buzzer will sound and further input will not be accepted.
- The decimal point will be placed on the third character from the right in each column any time **CODE 1+TAB** keys are used.

6 

After entering all of the data, press the **MENU** key to close the auto column.
The display will return to the Auto Column Plus Menu.

While creating your auto column, you can calculate using the entered data in this auto column. This operation will be covered in the next section.

• If an auto column file already exists in the memory at step 2, the display will show:

Auto Column file already exists in memory.
 This action will delete the existing file.
 Continue?
 Yes-RETURN / No-

To create the new auto column file, press the **RETURN** key.
 To retain the existing auto column file, press the **CANCEL** () key and the Auto Column Plus Menu will appear.

B To Calculate in an Auto Column

This unit will allow you to calculate while creating or editing an auto column.

In the Auto Column Plus mode, there are auto and manual calculation options available:

Horizontal sum, horizontal average, vertical sum, and vertical average are the auto calculations.

- Horizontal sum and average allow you to sum or average entire columns horizontally.
- Vertical sum and average allow you to sum or average entire rows vertically.
- Manual calculations (addition, subtraction, multiplication, division) allow you to calculate any values in the auto column into another position.

1 Perform the steps 1-5 of "To Create an Auto Column File" on p. 90.

10	I	*New File*								
:	A	:	B	:	C	:	D	:	E	:
1:										
2:	<input checked="" type="checkbox"/> Age		<input checked="" type="checkbox"/> 1987		<input checked="" type="checkbox"/> 1988		<input checked="" type="checkbox"/> Total		<input checked="" type="checkbox"/> Increase N	
3:										
4:	Twenties		<input checked="" type="checkbox"/> 1500		<input checked="" type="checkbox"/> 2000					
5:	Thirties		<input checked="" type="checkbox"/> 10000		<input checked="" type="checkbox"/> 15000					
6:	Forties		<input checked="" type="checkbox"/> 4500		<input checked="" type="checkbox"/> 7000					
7:	Fifties		<input checked="" type="checkbox"/> 2000		<input checked="" type="checkbox"/> 2300					
8:										
9:	<input checked="" type="checkbox"/> Total									
10:										

7

2 Press the **MAR REL** key to calculate.



H-Sum H-Avg. V-Sum V-Avg. Manual Calc.

3 **ARROW** keys (\leftarrow \rightarrow) Select the required expression by using the **ARROW** keys.

- H-Sum=Horizontal Sum
- H-Avg.=Horizontal Average
- V-Sum=Vertical Sum
- V-Avg.=Vertical Average
- Manual Calc.=Addition (+), Subtraction (-),
 Multiplication (*), Division (/)

For example:

When you want to enter the horizontal sum of columns B and C to the D column:





4a ARROW keys (←→) Select "H-Sum".

5a  Press the RETURN key.

H-Sum : █

6a  Enter "D" or "B,C=D" and press the RETURN key.
The display will show the results of calculation in "D" column.

OR



10	I	*New File*								
:	A	:	B	:	C	:	D	:	E	:
1:										
2:	C Age		C 1987		C 1988		C Total		C Increase N	
3:										
4:	Twenties		D 1500		D 2000		3500			
5:	Thirties		D 10000		D 15000		25000			
6:	Forties		D 4500		D 7000		11500			
7:	Fifties		D 2000		D 2300		4300			
8:										
9:	C Total									
10:										

When you want the amount of increase for "Twenties":

4b ARROW keys (←→) Select "Manual Calc." and press the RETURN key.



Manual Calc. : █

5b      Enter the calculating operation (Subtraction) as follows:

Manual Calc. : C4-B4=E4

6b 

Press the **RETURN** key.
The display will show the result of calculation.

10	I	*New File*			
:	A	B	C	D	E
1:					
2:	<input checked="" type="checkbox"/> Age	<input checked="" type="checkbox"/> 1987	<input checked="" type="checkbox"/> 1988	<input checked="" type="checkbox"/> Total	<input checked="" type="checkbox"/> Increase N
3:					
4:	Twenties	<input checked="" type="checkbox"/> 1500	<input checked="" type="checkbox"/> 2000	3500	500
5:	Thirties	<input checked="" type="checkbox"/> 10000	<input checked="" type="checkbox"/> 15000	25000	
6:	Forties	<input checked="" type="checkbox"/> 4500	<input checked="" type="checkbox"/> 7000	11500	
7:	Fifties	<input checked="" type="checkbox"/> 2000	<input checked="" type="checkbox"/> 2300	4300	
8:					
9:	<input checked="" type="checkbox"/> Total				
10:					

Repeat the above step to enter the amount of increase for all age groups.
When calculating is completed, the display will show:

10	I	*New File*			
:	A	B	C	D	E
1:					
2:	<input checked="" type="checkbox"/> Age	<input checked="" type="checkbox"/> 1987	<input checked="" type="checkbox"/> 1988	<input checked="" type="checkbox"/> Total	<input checked="" type="checkbox"/> Increase N
3:					
4:	Twenties	<input checked="" type="checkbox"/> 1500	<input checked="" type="checkbox"/> 2000	3500	500
5:	Thirties	<input checked="" type="checkbox"/> 10000	<input checked="" type="checkbox"/> 15000	25000	5000
6:	Forties	<input checked="" type="checkbox"/> 4500	<input checked="" type="checkbox"/> 7000	11500	2500
7:	Fifties	<input checked="" type="checkbox"/> 2000	<input checked="" type="checkbox"/> 2300	4300	300
8:					
9:	<input checked="" type="checkbox"/> Total				
10:					

7

When you want to enter the vertical sum of lines 4-7 on line 9:

4c ARROW keys (←→) Select "V-Sum".

5c  Press the **RETURN** key.

V-Sum : █

6c

(
9

Enter "9" or "4, 5, 6, 7 =9" and press the RETURN key.
The display will show the results of calculation on the ninth line:

OR

\$, i % , i €
4 , 5 , 6

, i & + \ (,)
, 7 = , 9

→ RETURN

10	I	*New File*			
:	A	B	C	D	E
1:					
2:	Age	1987	1988	Total	Increase N
3:					
4:	Twenties	1500	2000	3500	500
5:	Thirties	10000	15000	25000	5000
6:	Forties	4500	7000	11500	2500
7:	Fifties	2000	2300	4300	300
8:					
9:	Total	18000	26300	44300	8300
10:					

- You can use only numbers or numbers with a period (.:decimal point) and a hyphen (-:minus) as the objects of calculation. Numbers with "%", "\$", "()", "," can not be calculated in auto column. For example: "30%", "\$300", "A1-(B2+C3)=D4" "3,000"

- If there is an incorrect calculating expression, the display will show:

Parameter error!

7

7

MENU

After calculating and completing your table, press the MENU key. The display will show the Auto Column Plus Menu.

C To Print an Auto Column

You have now entered your auto column into memory and want to print it.

1

PRINT

Press the PRINT key after creating or editing the auto column. This display will show the printing parameters.

10 I Auto Column Plus

Left Margin : 0
Right Margin : (70)
Print Impression : 1 (1-Light/2-Medium/3-Heavy)

Set parameters then press RETURN. Press MENU to exit.

When you enter the left margin data, right margin data will change automatically.

2

RETURN

If all of the printing parameters are correct, press the RETURN key to start printing.

If not, select the desired parameter by using the ARROW keys, and change it.

- You can select the printing impression level, too.

When printing is completed, your auto column will reappear on the display.

D To Modify an Existing Auto Column

If you want to modify an existing auto column, do the following:

- 1 ARROW keys (↑ ↓) or Select "Edit File" in the Auto Column Plus Menu.

2

```
Auto Column Plus
1. Create File
2. Edit File
3. Load File from Disk
4. Store File to Disk

Select function then press RETURN. Press MENU to return to Main Menu.
```

- 2  Press the **RETURN** key.
The display will show the auto column table.

- 3 Modify the table.

4 

After modifying, press the **MENU** key to return to the Auto Column Plus Menu.

- If the part to be modified is located toward the end of the table, press the **RELOC** key to position yourself at the end line.
- If the part to be modified is located toward the beginning of the table, press the **CODE 1+RELOC** keys to position yourself at the first line.
- If the part to be modified is located toward the end of line, press the **CODE 1+RIGHT ARROW** keys to move to the end of it.
- If the part to be modified is located toward the beginning of the line, press the **CODE 1+LEFT ARROW** keys to move to the beginning of it.

7 E To Store an Auto Column File to the Disk

The unit allows you to store an auto column file created in the Auto Column Plus mode to the disk.

- 1 ARROW keys (↑ ↓) or Select "Store File to Disk" by using the **ARROW** keys or entering "4" in the Auto Column Plus Menu.

4

```
Auto Column Plus
1. Create File
2. Edit File
3. Load File from Disk
4. Store File to Disk

Select function then press RETURN. Press MENU to return to Main Menu.
```

- 2  Press the **RETURN** key.
The display will show "Reading disk.", and then the auto column file list will appear.

```
Store Auto Column File to Disk          Space Available = (KB)

Name          Size (KB)

File Name = █
```

- 3** ARROW keys (↑↓←→) or Enter the file name. Select the name of the auto column file to be loaded by using the **ARROW** keys or entering the name.

- 4**  Press the **RETURN** key.

Loading file.

When loading is completed, the display will show the column layout.

- If you already have an auto column in the memory, the display will show:

Auto Column file already exists in memory.
This action will delete the existing file.
Continue?

Yes-RETURN / No-

Press the **RETURN** key to load the auto column file.
Press the **CANCEL** () key to cancel this operation.

G To Delete an Auto Column from Memory

If you need to create a new auto column, you can simply delete the current auto column from memory as follows:

If you want to delete an auto column file from the disk, refer to "Deleting a File from the Disk" on p. 67.

- 1** ARROW keys (↑↓) or Select "Create File" and press the **RETURN** key.



Auto column file already exists in memory.
This action will delete the existing file.
Continue?

Yes-RETURN / No-

- 2**  Press the **RETURN** key to delete the auto column in memory and create a new auto column.
• If you do not wish to delete it, press the **CANCEL** () key.

8-1 THESAURUS

Words that have almost the same meaning are called synonyms. The Thesaurus will give you a list of synonyms so that you can select the one best suited for clear and effective expression.

The Thesaurus can be used even when Accu-Spell Plus is activated.

The Thesaurus does not work when a text is printing, or the Address List Memory or Auto Column Plus is activated.

Electronic Thesaurus licensed from Houghton Mifflin Company. U.S. Pat. No. 4,724,523. Copyright © 1985 by Houghton Mifflin Company. All rights reserved. Reproduction or disassembly of embodied algorithms or database prohibited. Based upon Roget's II: The New Thesaurus.

1a Position the carriage/cursor on the word or the space after the word. To select a synonym for a word, position the carriage/cursor on the word or on the space immediately following the word depending upon the mode you are in. (e.g. last)

2a  +  Press the **CODE 1+0** keys to activate the Thesaurus.

-OR-

1b  +  Just before typing a word you want to change, press the **CODE 1+0** keys.

2b  Type the word for which you want a synonym and press the **RETURN** key. (e.g. last)

3 The display will show. The Thesaurus will display a word type menu showing all the applicable word types (i.e.: adjective, adverb, noun and verb). Next to each word type is the number of synonym display lists available for that word.

```
THESAURUS  Enter Word = last
ADJECTIVE( 4)  ADVERB ( 1)  NOUN ( 1)  VERB ( 3)
```

•When the word has only one word type, the word type menu will not appear.

4 **ARROW** keys (←→) Select the type of the word by using the **ARROW** keys. Let us suppose that you have selected "ADJECTIVE (4)".

5  Press the **RETURN** key.

```
THESAURUS  Enter Word = last
ADJECTIVE ( 1/4)  hindmost  lattermost  rearmost
```

"ADJECTIVE (1/4)" indicates that the first of four synonym lists is now displayed.

•If the list is longer than what can be shown on the display, press the **DOWN ARROW** key to display the next part of the list.

6 ARROW keys (↑↓)

If you wish to see another list, press the **ARROW** keys to display it.

- You should understand that the four lists correspond to four different meanings of the adjective "last", while the words belonging to the same list differ only by subtle nuances.

7 ARROW keys (←→)

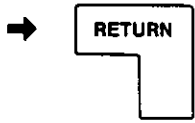

Select a synonym by using the **ARROW** keys and press the **RETURN** key.

The selected adjective replaces "last", appears on the display or is printed. Then Thesaurus is deactivated.

- You can always cancel this operation by pressing the **CANCEL** (⊗) key.
- If no synonym is found, the display will show:

No synonyms found!

- When the word designated in your text is not in the simple grammatical form (e.g. "worked" instead of "work"), the synonyms are displayed in the same grammatical form. This is valid for all verb forms, nouns, plurals and "s" endings.
- When substituted in a text, a synonym will respect the attributes of the old word (bold, underline, etc.) as well as the capitalization.
- The following example shows how a word is designated according to the carriage/cursor position when you press the **CODE 1+0** keys.

...take over the family business.

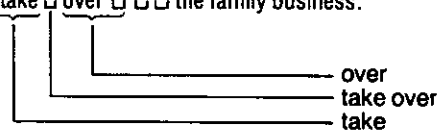

over
take over
take

9-1 ACCU-SPELL PLUS™ (Spell Verifying/Correcting Feature)



When you misspell a word in either the Typewriter Mode or Word Processor Mode, Accu-Spell Plus informs you by means of an indication on the display and a buzzer. By using the Accu-Spell Plus function, you can easily replace misspelled words with the correct spelling. The typed words are checked against the basic dictionary, which contains about 63,000 words, and a user's dictionary of up to 120 words.

The user's dictionary can be deleted and changed, and a list of user's dictionary words can be printed or displayed.

• Accu-Spell Plus™ is a trademark for the Spell Correct Function in the U.S.A.

• The following functions are available for Accu-Spell Plus™ by pressing the **CODE 1** or **CODE 2** keys with an appropriate key.

 +  Activates or cancels Accu-Spell Plus.

 +  Lists the words contained in the user's dictionary.

 +  Adds a word to the user's dictionary.

 +  Displays suggested spellings when Accu-Spell Plus judges a word to be spelled incorrectly.

 +  Checks the spelling of an entire text file.

Accu-Spell Plus operates when you make an input from your keyboard.

It does not work when a text is printing, or the Address List Memory or Auto Column Plus function is activated.

International CorrectSpell™ English licensed from Houghton Mifflin Company. U.S. Pat. No. 4,580,241, 4,730,269, and 4,771,401. Copyright © 1985, 1987, 1988, 1989 by Houghton Mifflin. All rights reserved. Reproduction or disassembly of embodied algorithms or database prohibited. Based upon The American Heritage Dictionary.

• International CorrectSpell™ is an HMCo trademark.

NOTE:

All information stored in the memory is cleared when the **POWER** switch is turned **Off**. For permanent storage, User's Dictionaries created with Accu-Spell Plus must be stored to the micro-floppy disk.

A Accu-Spell Plus Operation

1  +  Press the **CODE 2+0** keys.
The display message "SPELL" will appear on the status line.

2 While Accu-Spell Plus is activated, enter the words as usual.

3  or



When you end a word (by pressing the **SPACE BAR** or **RETURN** key, etc.), it will be checked.

- If the word is not contained in either the basic dictionary or the user's dictionary, the unit will judge it to be a misspelled word, the buzzer will sound and the word will flash on the display.

In the normal typing mode, a misspelled word will be displayed without flashing as follows. (Except in the Word Processor Mode)

Error: (word)

- If the word is found in either the basic dictionary or user's dictionary, the buzzer will not sound and the display will remain unchanged.

- If the **RETURN** key is pressed immediately after typing a misspelled word, the buzzer will sound but the word will not flash on the display. (Except in the Word Processor Mode)

4  +  Press the **CODE 2+9** keys.

Searching alternatives.

After a few seconds, some correctly spelled words will show at the bottom of the display.

- If the desired word is not displayed, press the **UP/DOWN ARROW** keys to display the next set of suggestions.

Repeat this operation until the desired word is displayed.

When Accu-Spell Plus has no more suggested spellings, the display will show:

No more alternatives.

In this case, press the **CANCEL** () key and use the ordinary correction method.

5 **ARROW** keys ( )

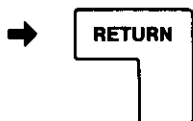

Select the desired word by using the **ARROW** keys and press the **RETURN** key. The misspelled word will be replaced with the correct one.

- You can correct the misspelled word while it is flashing.
- If the length of the correct word is different from the misspelled word in the "NORM" mode, the misspelled word and the following characters are deleted and reprinted. (Except in the Word Processor Mode.)
- If the word to be inserted is longer than the misspelled word, causing the line to go past the right limit margin, the display will show:

Word too long!

Word Endings

Accu-Spell Plus checks a word only when it has been completed.

The unit judges that a word has been completed when you perform one of the following operations:



- when you press the **SPACE BAR** after a word
- when you press the **RETURN** key
- when you press a function key to move the carriage/cursor (**TAB**, **SPACE BAR**, etc.)
- when you perform right margin flush or centering

When you enter a character after entering a hyphen at the end of a line, an automatic return is performed and the word is connected to the beginning of the next line, and will be spell verified as a single word.





Accu-Spell Plus checks spelling according to the following rules.

- Numbers and symbols are also treated as part of a word. For example, "etc" is treated as a mistake while "etc." is judged correct.
- Symbols before and after a word such as " " (quotation mark) and ? (question mark) are first removed from the word before it is spell verified. For example, "Great!!" is judged correct, but "Gleat!!" is judged incorrect.
- Some punctuation errors are detected. For example, "word:)" is judged as an error and the buzzer will sound.
- Some errors of apostrophe are detected. For example, "now's" and "at's" will be judged incorrect.
- A word consisting of several words joined by hyphens, such as "mother-in-law", is spell verified as a single compound word.
- Accu-Spell Plus takes into account the difference between capital letters and small letters.
If you type "check, Check, CHECK", all of these words will be judged correct. This is because when a word is at the beginning of a sentence, it starts with a capital letter, while if it is part of a title it consists entirely of capital letters. If, however, you type "CHeck", it will be judged incorrect.
- In the case of words which always begin with a capital letter, such as America, both "America" and "AMERICA" will be judged correct, however "america" will be judged incorrect.

B How to Verify/Correct the Spelling of an Entire Text

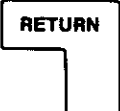

-  → Load a text. While Accu-Spell Plus is activated, press the **MENU** key, and then load a text file to be verified from disk.
- Move the cursor to the desired position to start the check.
-  +  Press the **CODE 1+F** keys.
- The text is verified. Each word in the text will be verified from the cursor position sequentially to the end of the text.

Verifying

- A misspelled word is found. If a word that is not in the dictionary is found, spell verification will be interrupted, the buzzer will sound twice, and the word will appear as a flashing indication on the display.
-  + 
→  Correct the misspelled word by pressing the **CODE 2+9** keys and the **RETURN** key.
-  +  To continue spell verification, press the **CODE 1+F** keys again.
- If no misspelled words are found... If no misspelled words are found in any part of the text, the following message will appear on the display, and the cursor position remains unchanged.

Verify end.

C How to Add Words to the User's Dictionary

- Enter the word to be added.
-  +  Press the **CODE 2+8** keys.
- The word will be added to the user's dictionary.

Added: (the added word)

- You can add a word by pressing the **CODE 2+8** keys immediately after the check.
- You can also add a word by first moving the carriage/cursor to the desired word and then pressing the **CODE 2+8** keys.
- You can also add words which include numbers and symbols, but at least two alphabet characters should be included for registration. Otherwise the display will show:

Not accepted!

- If there is no room in the user's dictionary memory to add the word, the buzzer will sound and the display will show:

User's dictionary full!

In this case, you must first delete a word or words already registered in order to add the new word.

- If the word which you want to add is already contained in the basic dictionary or User's Dictionary, the display will show:

Already exists!

- You can add a word up to a maximum of 30 characters long. If you attempt to add a word of more than 30 characters, the display will show:

Word too long!

- When you attempt to add a symbol such as "↵" or "☐" etc., the display will show:

Not accepted!

- If a word surrounded by punctuation [e.g. (XXX) or "XXX,"] is added to the user's dictionary, the entire sequence including punctuation will be added. Therefore, it is best not to add words that are surrounded by punctuation. If an entry including punctuation is added, a later occurrence without punctuation will be beeped. In such a case, add the later example and delete the earlier form.

D How to List Words in the User's Dictionary

How to Display the Contents of the User's Dictionary

1  + 

Press the **CODE 2+7** keys. The first 5 words in the user's dictionary will appear on the display in alphabetical order.



2  //  + 

Each time you press the **NEXT PAGE** key or the **CODE 1+NEXT PAGE** keys, the next page or the previous page of words will be displayed.

- If there are no words in the User's Dictionary, the display will show:

User's dictionary empty!

How to Print the Contents of the User's Dictionary

- 1  While in the list mode, press the **PRINT** key to start printing from the first word.
- 2  If you want to stop printing, press the **PRINT** key. Printing will temporarily stop.
 - Printing will stop after printing 50 lines, and then the display will show "Page End!".To continue printing, insert a new sheet of paper and press the **RETURN** key.
To cancel printing, press the **CANCEL** () key.

How to Exit the List Mode

- 1  +  While in the list mode, press the **CODE 2+7** keys.

E How to Store a User's Dictionary File to the Disk

The unit allows you to store the User's Dictionary file to the disk.

- 1  Press the **MENU** key.

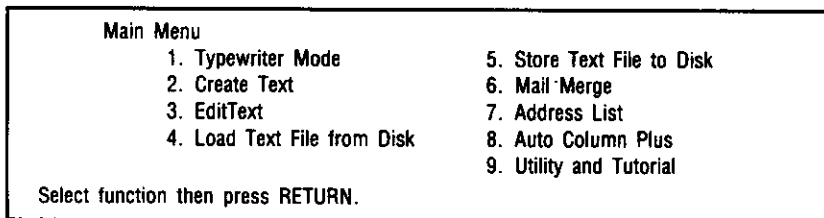

- 2 **ARROW** keys () Select "Utility and Tutorial" by using the **ARROW** keys or entering "9".

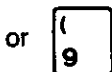

- 3  Press the **RETURN** key.

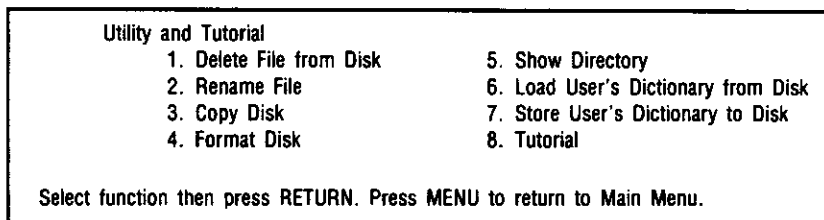

- 4 **ARROW** keys () Select "Store User's Dictionary to Disk" by using the **ARROW** keys or entering "7".



5 

Press the **RETURN** key.
The display will show "Reading disk." and then the User's Dictionary file list will appear.

Store User's Dictionary File to Disk		Space Available =	(KB)
Name	Size (KB)		
Dic. Name = █			

6 Enter the file name.

7 

Press the **RETURN** key.

Storing file.

The display will return to the Utility Menu after the file has been stored to the disk.

- Press the **MENU** key to cancel this operation.
- If you store a User's Dictionary file from the memory to the disk and the same name is already stored on the disk, the display will show:

Same file name already exists on the disk. Do you want to replace the existing file with the new file in memory? File Name = Yes-RETURN / No- <input checked="" type="checkbox"/>

- If you want to rename the file, refer to "Renaming a File" on p. 63.

F How to Load a User's Dictionary File from the Disk

When you have stored a User's Dictionary file from the memory onto the disk, you may clear your memory and continue with additional projects. The disk drive gives you the ability to take a User's Dictionary file stored on the disk, and load it back into memory whenever you need it.

1 

Press the **MENU** key.

Main Menu	
1. Typewriter Mode	5. Store Text File to Disk
2. Create Text	6. Mail Merge
3. EditText	7. Address List
4. Load Text File from Disk	8. Auto Column Plus
	9. Utility and Tutorial
Select function then press RETURN.	

9

2 ARROW keys (↑↓←→) Select "Utility and Tutorial" by using the **ARROW** keys or entering "9".

or 

3  Press the **RETURN** key.

```
Utility and Tutorial
 1. Delete File from Disk      5. Show Directory
 2. Rename File              6. Load User's Dictionary from Disk
 3. Copy Disk                 7. Store User's Dictionary to Disk
 4. Format Disk               8. Tutorial

Select function then press RETURN. Press MENU to return to Main Menu.
```

4 ARROW keys (↑↓←→) Select "Load User's Dictionary from Disk" by using the **ARROW** keys or entering "6".

or 

5  Press the **RETURN** key.
The display will show "Reading disk." and then the User's Dictionary file list will appear.

```
Load User's Dictionary File from Disk      Space Available = (KB)
Name      Size (KB)
Dic. Name = █
```

6 ARROW keys (↑↓←→) Select the name of the file to be loaded by using the **ARROW** keys or entering the name.

or
Enter the file name.

7  Press the **RETURN** key.

```
Loading file.
```

The display will return to the Utility Menu after the file has been loaded from the disk.

G How to Delete Words from the User's Dictionary

1  +  Press the **CODE 2+7** keys.













































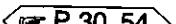

2 ARROW keys (↑↓) Select the word to be deleted by using the **ARROW** keys.

3  Press the **CANCEL (X)** key.
The selected word will be deleted from the User's Dictionary.

•While displaying a list of the registered words, you can delete a word by selecting it with the **ARROW** keys and then pressing the **CANCEL (X)** key.

























10-1 LIST OF CODE KEY FUNCTIONS

A List of CODE 1 Key Functions































 + A AUTOsets/releases auto carrier return mode in the typewriter mode	 P.33
 + B BOLDsets/releases BOLD print	 P.29, 54
 + C CENTERcenters information	 P.31~32, 55~56
 + E EMBEDembeds the display symbols	 P.36, 59
 + F FINDfinds misspelled words (in edit mode)	 P.101, 104
 + Gdisables the status and ruler lines information on the 7th line in text edit mode	 P.42
 + H HALF SPhalf spacing	 P.35, 59
 + I INDENTsets/releases paragraph indent	 P.34, 57
 + J MICRO SPmoves the carriage by $\frac{1}{60}$ inch (micro spacing)	 P.35, 59
 + Kstores line spacing to text	 P.51
 + L MARGINchanges margin format	 P.25, 40, 50
 + Orecalls margin format O	 P.40, 50
 + P STOPsets a stop code in a text	 P.53
 + Qinputs sort rectangle	 P.82
 + R RMTprints information with the last character on each line aligned at the right margin	 P.33, 56
 + S SEARCHsearches for words in a textsearches for strings in a record of address list	 P.46  P.83
 + T APPENDtext append	 P.65
 + U UNDETsets/releases continuous underlining	 P.30, 54
 + Vreference code for mail merge	 P.69, 75
 + W WDWsets/releases word by word underlining	 P.30, 54
 + X REPLACreplaces a word/words in a text	 P.47
 + Yrecalls margin format Y	 P.25, 40, 50
 + Zrecalls margin format Z	 P.25, 40, 50

- + sets/releases the insert/over typing
- + moves information block in a text
- + copies information block in a text
copies a record to another record
- + deletes information block in a text
- + sets page break
- + sets page length
- + jumps to desired page
- + controls the impact of the printed characters
- + enables the Thesaurus feature
- + displays the layout of text
- + reverse word by word scroll
- + forward word by word scroll
- + makes correction manually in the typewriter mode.
deletes a record in address list.
- + permanent hyphen
- + permanent space
- + aligns decimal points at preset tab stops
- + clears all tabs and margins
- + auto paper insertion
searches for the return mark while executing the word search command or the word replace command
- + presets the unit for typing capital letters, lower case numbers, punctuation marks and symbols
- + next search word (in edit mode)
- + previous search word (in edit mode)
- + express return

0

-  +  Mail merge record header  P.70
-  +  scrolls to the previous page  P.45
-  scrolls to the previous RECORD of address list  P.81
-  scrolls to the previous page of words in user's dictionary  P.105
-  +  scrolls to the previous display  P.45
-  +  scrolls to the next display  P.45
-  +  advances the cursor to the beginning of the line  P.46
-  +  advances the cursor to the end of the line  P.46
-  +  deletes one line at a time  P.29, 43

B List of CODE 2 Key Functions

-  +  selects typing mode  P.17
-  +  selects pitch  P.17
-  +  selects line spacing  P.18
-  +  selects keyboard  P.18
-  +  sets the left margin  P.24
-  +  sets the right margin  P.24
-  +  lists the words in the user's dictionary  P.105
-  +  registers a word in the user's dictionary  P.104
-  +  display suggested spellings  P.102, 104
-  +  spell verify/correct ON/OFF  P.102

10-2 LIST OF DISPLAY MESSAGES

Message	Description
Added :	A word has been added to the user's dictionary.
Already exists!	The entered word is already contained in the dictionary.
Appending text.	The machine is appending a document into a text.
AUTO	Auto carriage return mode is in operation.
BOLD	Bold print is in operation.
Can not copy!	Cannot copy a document into the body of a text.
Cannot set here!	You have tried to change the margin format or the line spacing in an illegal area inside a text.
CENTER	Centering is in operation.
Centering Between Words	You can center information between words.
Change margin format, Y/Z/O (original)?	Do you want to change the margin format stored in the text?
CHECK PLATEN !	Something is wrong with the mechanical line space. Please check it.
CHECK RIBBON !	Something is wrong with the ribbon cassette or the correction tape.
CODE 1	CODE 1 key is pressed.
CODE 2	CODE 2 key is pressed.
CODE 1+ / not found in the mail list	There are no records in the Mail List.
CP. LOCK	Caps lock mode is activated.
Current Word =	Enter the word or words you want to replace.
DECTAB	Decimal tabulation is in operation.
Deleting file.	The machine is deleting a file from the disk.
Directory full!	The maximum of 112 files were entered on the disk directory.
Disk error!	Information cannot be accessed or the disk is not formatted.
Enter Word =	Enter the word for which you want a synonym.
Formatting disk.	The machine is formatting a disk.
Impression	Select the desired typing impression (light, medium or heavy).
INDENT	Paragraph indent is in operation.
INS.	Insert typing mode is in operation.
Line Space :	Select the desired line spacing (1, 1.5 or 2).
Loading file.	The machine is loading a file from the disk into the memory.
LOCK.	LOCK key is pressed.
Machine is busy!	The machine is operating. Please wait.
Mail List =	Enter the name of the mail list you want to merge with a letter.
Manual Correction Mode	You can make corrections on a previous line.
MARGIN OVER	You have exceeded the right margin.
Memory full!	Entire memory capacity has been used.
New Name =	Enter the new name for a stored file.
No disk!	Floppy disk is not inserted to the disk drive.
No files in memory!	There is no file to be stored to disk.
No files on the disk!	There are no files on the disk.
No more alternatives	The standard and user's dictionaries have no more alternatives.
No Print Mode	Manual correction without printing is in operation.
No qualified records!	A qualified record does not exist in the mail list.
No synonyms found!	The word has no synonyms.
Not accepted!	The entered word contains illegal characters.
Not found!	The required word is not within this text or address list or the file is not on the disk. The entered word does not exist in the user's dictionary.

10

Message

Description

Page end!	The end of the page has been reached during printing.
Page Length =	Enter the number of lines per page.
Page Number =	Enter the page number you wish to jump to or print to/from.
Parameter error!	There is an incorrect parameter.
Printing!	The machine is printing.
Protected disk!	The inserted disk has been protected. You cannot write, clear, rename or format on this disk.
Qualifier :	Enter the qualifying fields you want to select from.
Reading disk.	The machine is reading the file from the disk into memory.
Reading source disk.	The machine is reading the source disk in the disk copy operation.
Record No. =	Enter the record number you want to copy.
Reference code mismatch!	The form letter includes more reference codes than variables included in a mail list record.
Renaming file.	The machine is renaming a file.
Replace Word =	Enter the word or words you want to insert.
R.M.F.	Right margin flush is in operation.
Searching alternatives.	The machine is searching for the suggested spellings.
Searching records.	The machine is searching for the desired records.
Search Word =	Enter the information you want to search for.
Sorting records.	The machine is sorting the records.
Space available	The numeric value represents the remaining capacity on the disk.
SPELL	Accu-spell plus is in operation.
Store current margin format to Y/Z?	In which location do you want to store the margin format?
Storing file.	The machine is storing the file in memory onto disk.
Term too long!	The entered characters are too long.
Too many records!	You have tried to enter more than the maximum number of records.
Too many tab stops!	You have tried to enter more than the maximum number of tab stops.
Top of list!	This is the top of the address list.
User's dictionary empty!	There are no words in the user's dictionary.
User's dictionary full!	There is no more memory in the user's dictionary.
Verify end	Verifying is completed.
Verifying	The machine is verifying.
Word too long!	The entered word is too long (greater than 30 characters).
Writing destination disk.	The machine is writing the destination disk.
<u>XX XX</u>	Continuous underlining is in operation.
<u>XX XX</u>	Word by word underlining is in operation.

10-3 OTHERS

A Troubleshooting

• Check the points below before returning your unit for service.

Symptom	Cause	Remedy/check
No operations; even when keys are pressed, nothing appears on the display.	The POWER switch is turned "OFF" or the power cord is unplugged.	Turn the POWER switch "ON". Plug in the power cord.
	The LCD contrast control is set to low contrast.	Adjust the setting of the LCD contrast control.
	The lid is open.	Close the lid.
Unit does not print correctly, or printing is blurred.	Paper release lever is in release position.	Push lever to lock position.
	End of ribbon cassette or correction tape.	Replace with new ribbon cassette or correction tape.
No deletion even with the CANCEL (⊗) keys; blurred characters.	Correction tape is not installed, or installed incorrectly.	Install correction tape.
Buzzer sounds during typing and typing is disabled (keys do not function).	Carriage at right margin.	Press the RETURN key and move carriage to next line.
		Press the MAR REL key and continue printing on same line.
	Text memory is full.	Re-edit the data or cancel the memory mode.

B Product Service

Should your Panasonic product ever require service, refer to the directory for an Authorized Servicenter or consult your authorized Panasonic dealer for additional information.

10-4 OPTIONAL ACCESSORIES

Part No.	Description	Comment
KX-R10	Daisywheel Printing Element COURIER 10	1 unit
KX-R11	PRESTIGE PICA 10	1 unit
KX-R12	PRESTIGE ELITE 12	1 unit
KX-R13	SCRIPT 10/12	1 unit
KX-R14	GOTHIC 15	1 unit
KX-R15	ORATOR 10	1 unit
KX-R16	BERLIN ITALIC 10/12	1 unit
KX-R20	Correctable Film-Ribbon Cassette	1 unit
KX-R21	Fabric Ribbon Cassette	1 unit
KX-R30	Lift-off Correction Tape	2 units
KX-R31	Cover-up Correction Tape	2 units
KX-R50	Correctable Film-Ribbon Cassette	2 units
KX-R51	Correctable Film-Ribbon Cassette	3 units
	Lift-off Correction Tape	2 units
KX-R52	Correctable Film-Ribbon Cassette	3 units
	Lift-off Correction Tape	2 units
	Daisywheel (KX-R13)	1 unit

10-5 SPECIFICATIONS

Print Element:	Daisywheel; 96 characters
Print Speed:	12 cps
Print Pitch:	10, 12, 15
Line Spacing:	1, 1½, 2
Paper Width:	12"
Writing Line:	10"
Ribbon:	Correctable Film-Ribbon, Fabric Ribbon (Optional)
Correction Tape:	Lift-off Tape, Cover-up Tape (Optional)
Operating Modes:	Typewriter Mode, Word Processor Mode
Correction Memory:	1 line
Text/Address List Memory:	36,000 Characters
Disk Drive:	3.5" 1DD Micro-Floppy Disk, 353 KB/disk
Built-in Dictionary:	63,000 words
User Dictionary:	120 words
Display Type:	Liquid Crystal Display with contrast control
Display Size:	80 chr. x 7 lines
Power Requirements:	AC 230 ± 10% 50Hz
Power Consumption:	35 W (Approx. 3 W: When the power switch is turned off)
Operating Temperature:	41°F (5°C) to 95°F (35°C)
Operating Humidity:	20 to 80% RH
Storage Temperature:	-4°F (-20°C) to 140°F (60°C)
Dimensions:	17" (W) x 15½" (D) x 4½" (H) (432 x 395 x 118 mm)
Weight:	14½ lbs. (6.5 kg)

10-6 INDEX

- A** Accent Symbols 18
 Access Indicator 9
 Accessories 115
 Accu-Spell Plus™ 101
 Verify/Correct the Spelling of
 an Entire Text 104
 Word endings 103
 AC Power cord 13
 ADDRESS LIST 77
 Appending Text 65
 Auto Carriage Return 33
 AUTO COLUMN PLUS 89
 Auto paper insertion 15
- B** **BACKSPACE** key 11
 Block Modifying
 Block copy 49
 Block delete 49
 Block move 48
 Bold Print (TPWR) 29
 (WP) 54
- C** **CANCEL** (⊗) key 11
 Caps Lock (TPWR) 35
 (WP) 58
 Carriage 8
 Carriage Return 33
 Carriage Stopper 2
 Carrying Handle 9
 Centering
 Auto Half Space 32
 Between Margins (TPWR) 31
 (WP) 55
 Between Tab Stops (TPWR) 31
 (WP) 56
 Over a Specified Point (TPWR) 32
 (WP) 56
CODE 1 key 10
CODE 2 key 10
 Copy
 Block copy 49
 Disk copy 66
 Record copy 84
 Correction
 Manual Correction 26
 One Line Erase (TPWR) 29
 (WP) 43
 Quick Erase (TPWR) 29
 (WP) 42
 Using No Print method 27
- Within correction memory
 On the display (TPWR) 28
 (WP) 42
 Correction Tape 14
 Cursor (TPWR) 23
 (WP) 39
- D** Daisywheel 14
 Dead keys 18
 Decimal Tabulation (TPWR) 30
 (WP) 55
 Deleting
 An auto column 98
 A record 87
 A text 52
 Information block 49
 Words from user's dictionary 108
 Display Messages (TPWR) 23
 (WP) 39
 Display Symbols (TPWR) 23
 (WP) 39
 Display Typing Mode 17
DOWN ARROW key 11
- E** Eject Button 9
Express key 11
- F** Form Letter 69
FORWARD key 11
 Function keys 10
- H** Half Space (TPWR) 35
 (WP) 59
 Hard Cover 2
HELP key 11, 20
 Hot Zone 25
- I** **INDEX** key 11, 26
 Insert Typing 41
- J** Justify Typing Mode 17
- K** KBI 18
 KBII 18
- L** LCD 8
 LCD Contrast Control 8
LEFT ARROW key 11
 Line Spacing 51
 List
 Address lists 85
 File names 64
 User's dictionary 105

M	Mail List	70
	Mail Merge	
	Dummy text	75
	Form letter	69
	Mail list	70
	Merging form letter and mail list	71
	Printing envelopes and labels	75
	Qualifier	73
	Record	70
	Reference Code	69
	Selecting from qualified mail list	73
	Wildcards	74
	Main Menu	11, 19
	Margin Format (TPWR)	24
	(WP)	40
	Clearing	24
	Setting	24
	Storing/Changing (TPWR)	25
	(WP)	50
	MARGIN RELEASE key	10
	MENU key	11
	Micro-Floppy Disk	
	Copying a disk	66
	Deleting file from disk	67
	Formatting	60
	Inserting a disk	16
	List printing	65
	Listing	64
	Loading a file from disk (Text)	62
	(Address List)	81
	(Auto Column)	97
	(User's Dictionary)	107
	Protecting from Erasure	16
	Renaming a file	63
	Storing files to disk (Text)	61
	(Address List)	78
	(Auto Column)	96
	(User's Dictionary)	106
	Micro-Floppy Disk Drive	9
	Micro Spacing (TPWR)	35
	(WP)	59
N	NEXT PAGE key	10
	Normal Typing Mode	17
O	Overtyping	41

P	Page Break	51
	Page Length	50
	Paper Bail	8
	Paper Bail Lever	8
	Paper Bail Rollers	8
	Paper Guide	8, 15
	Paper Release Lever	8
	Paper Support	8
	Paragraph Indent (TPWR)	34
	(WP)	57
	Permanent Hyphen (TPWR)	34
	(WP)	58
	Permanent Space (TPWR)	35
	(WP)	58
	Pitch Scale	8
	Platen	8
	Platen Knob	8
	Power Switch	13
	PRINT key	10
	Printing	
	ADDRESS LIST	85
	AUTO COLUMN	95
	Envelopes and labels	76
	File name list	65
	Halt printing	44
	Text	44
	User's dictionary	106
Q	Qualifier	73
	QUICK ERASE key	11
R	Record	77
	Reference Code	69
	RELOC key	11
	RETURN key	11
	REVERSE INDEX key	10, 26
	Ribbon Cassette	13
	Ribbon Cassette Stopper	2
	RIGHT ARROW key	11
	Right Margin Flush (TPWR)	33
	(WP)	56
	Ruler Line (TPWR)	23
	(WP)	38

S	Scrolling	
	To the beginning of the line	46
	To the desired page	45
	To the end of the line	46
	To the next display	45
	To the next page	45
	To the previous display	45
	To the previous page	45
	SHIFT key	10
	SHIFT LOCK key	10
	SPACE BAR	10
	Stop Code	53
	Storage Compartment	9
	Subscript	26
	Superscript	26
T	Tab	
	Centering between (TPWR)	31
	(WP)	56
	Clearing	24
	Decimal (TPWR)	30
	(WP)	55
	Setting	24
	TAB key	10
	TAB CLEAR key	10
	TAB SET key	10
	Text	
	Continuing a text	43
	Clearing	52
	Closing	41
	Modifying	45
	Printing	44
	Renaming	63
	Stop printing	44
	Text Memory	40
	Thesaurus	99
	Typewriter Mode	22
	Typing Impression Control (TPWR)	36
	(WP)	59

U	Underlining	
	Continuous (TPWR)	30
	(WP)	54
	Word by Word (TPWR)	30
	(WP)	54
	UP ARROW key	11
	User's Dictionary	
	Adding words	104
	Deleting words	108
	Listing	105
	Loading from disk	107
	Printing	106
	Storing to disk	106
W	Word Processor Mode	19, 37
	Word Replace	47
	Word Search	46
	Word-Wrap	52